

TALENT



ACTIU

TALENT

Created to create

ALEGRE DESIGN

www.alegreddesign.es

Talent was created to consolidate a single solution that met all the arising needs in spaces that aim to motivate critical thinking, innovation and the transfer of knowledge in a much more active, fun and creative way.

Talent nace para concentrar en un único producto todas las necesidades que surgen en los espacios que pretenden motivar el pensamiento crítico, la innovación y la transmisión de conocimientos de una manera nueva, más activa, divertida y creativa.

Talent est né pour concentrer dans un seul produit tous les besoins requis par des espaces censés motiver la pensée critique, l'innovation, la transmission des connaissances ; tout cela d'une manière novatrice, bien plus active, amusante et créative qu'avant.

Talent ist entstanden, um alle Bedürfnisse, die in Räumen entstehen, die kritisches Denken, Innovation, Wissensvermittlung motivieren sollen, auf eine neue Art und Weise zu bündeln, und zwar viel aktiver, unterhaltsamer und kreativer als bisher.



CULTURAL TRANSFORMATION IS PROMOTED BY MEANS OF THE FLEXIBILITY OF THE SPACES.

LA TRANSFORMACIÓN CULTURAL SE IMPULSA A TRAVÉS DE LA FLEXIBILIDAD DE LOS ESPACIOS.



SERIE 500

THE TALENT 500 LIFTING SYSTEM DOES NOT REQUIRE AN ELECTRICAL CONNECTION.

The height of the table can be regulated by means of an easy-to-use gas piston. This makes it possible to work standing up without the need for nearby power outlets.



El sistema de elevación de Talent 500 no precisa de conexión eléctrica. Mediante un pistón de gas de fácil utilización se regula la altura de la mesa. Esto posibilita trabajar de pie sin la necesidad de tomas de corriente cercanas.

Le système de réglage en hauteur de Talent 500 n'a pas besoin de branchement électrique. Grâce à un vérin à gaz simple à utiliser, il est facile de régler la table en hauteur. Cela permet de travailler debout sans avoir besoin de prise de courant à proximité.

Das Talent 500 Hubsystem erfordert keinen elektrischen Anschluss. Mit der Hilfe eines einfach zu bedienenden Gaskolben wird die Höhe des Tisches reguliert. Dadurch ist es möglich, im Stehen zu arbeiten, ohne dass Steckdosen in der Nähe benötigt werden.





Talent is made from a very resistant aluminium structure and a melamine surface with rounded corners and rubber edges to prevent injuries. Furthermore, it has a stand format, as well as the possibility of choosing surfaces that can be written on.

Talent está fabricada con una estructura de aluminio muy resistente y una superficie de melamina con forma redondeada en sus esquinas y cantos de goma para evitar lesiones. Además, dispone de un formato atril, así como la posibilidad de escoger superficies pintables.

Talent est fabriquée à l'aide d'une structure en aluminium très résistante et d'une surface en mélamine à forme arrondie dans les coins et bords en caoutchouc afin d'éviter tout risque de blessure. De plus, elle possède un format pupitre et la possibilité de choisir des surfaces peignables.

Talent besteht aus einer sehr widerstandsfähigen Aluminiumstruktur und einer Melaminoberfläche mit abgerundeten Ecken und Gummikanten, um Verletzungen zu vermeiden. Darüber hinaus verfügt es über ein Rednerpult Format sowie die Möglichkeit, lackierbare Oberflächen zu wählen.





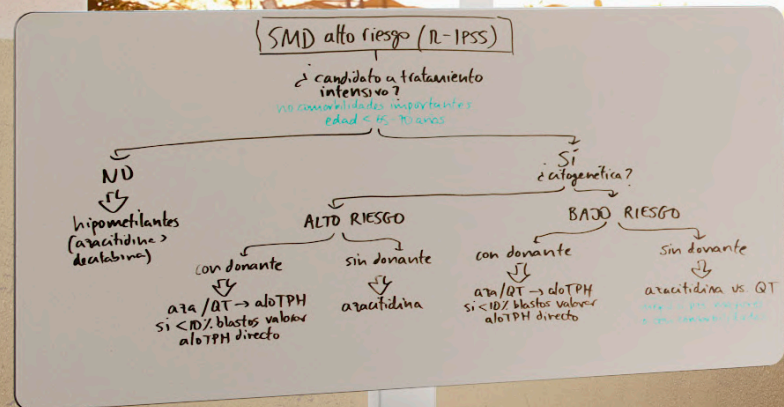
Talent is unique on the market by introducing a high technical performance table in training spaces. Adjustable, mobile and folding tables that have been designed for the customization of spaces and the application of learning methods based on practical intelligence.

Talent es único en el mercado al introducir una mesa con tal altas prestaciones técnicas en espacios de formación. Mesas elevables, móviles y abatibles diseñadas para la personalización de los espacios y la aplicación de métodos de aprendizaje basados en la inteligencia práctica.

Talent est unique sur le marché, car il introduit une table aux prestations techniques supérieures dans des espaces de formation. Des tables réglables, mobiles et rabattables, conçues pour la personnalisation des espaces et l'application de méthodes d'apprentissage basées sur l'intelligence pratique.

Talent ist einzigartig auf dem Markt, einen Tisch mit einer so hohen technischen Leistung in Seminarräumen einzuführen. Hub-, Mobil- und Klappische für die Personalisierung von Räumen und die Anwendung von Lernmethoden auf der Grundlage praktischer Intelligenz.









SERIE 300

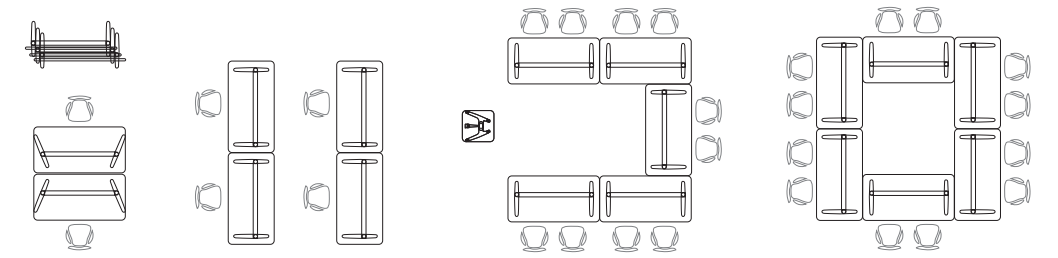
PRACTICAL INTELLIGENCE.

Talent allows to enhance individualized training, the personalization of content and the development of one's own skills, establishing learning methods based on practical intelligence so that students can discover their creative potential.

Talent permite potenciar la formación individualizada, la personalización de los contenidos y el desarrollo de las habilidades propias, estableciendo métodos de aprendizaje basados en la inteligencia práctica para que los alumnos descubran su potencial creativo.

Talent permet de favoriser la formation individuelle, la personnalisation des contenus et le développement des capacités personnelles en établissant des méthode d'apprentissage basées sur l'intelligence pratique, afin que les élèves puissent découvrir leur potentiel créatif.

Talent ermöglicht es, individualisierte Ausbildung, die Personalisierung der Inhalte und die Entwicklung der eigenen Fähigkeiten zu fördern und Lernmethoden auf der Grundlage praktischer Intelligenz zu etablieren, damit die Teilnehmer ihr kreatives Potenzial entdecken können.



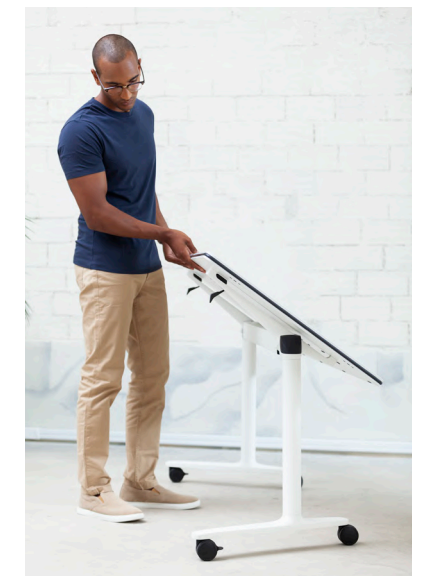


For ease of maintenance and storage, Talent is stackable. The aluminium legs are designed to allow several users to work without disturbance or discomfort.

Para facilitar su mantenimiento y almacenaje, Talent es apilable. Sus patas de aluminio están diseñadas para que varios usuarios puedan trabajar sin interferencias ni molestias.

Afin de simplifier entretien et stockage, Talent est empilable. Ses pieds en aluminium ont été conçus pour que plusieurs utilisateurs puissent travailler sans interférence ni gênes.

Für eine einfache Wartung und Lagerung ist Talent stapelbar. Die Beine aus Aluminium sind so konzipiert, dass mehrere Benutzer störungsfrei und ungestört arbeiten können.





SERIE 100

THE TALENT 100 MODEL IS PERFECT FOR TRAINING SPACES AND EDUCATIONAL CENTRES.

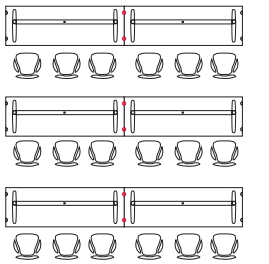
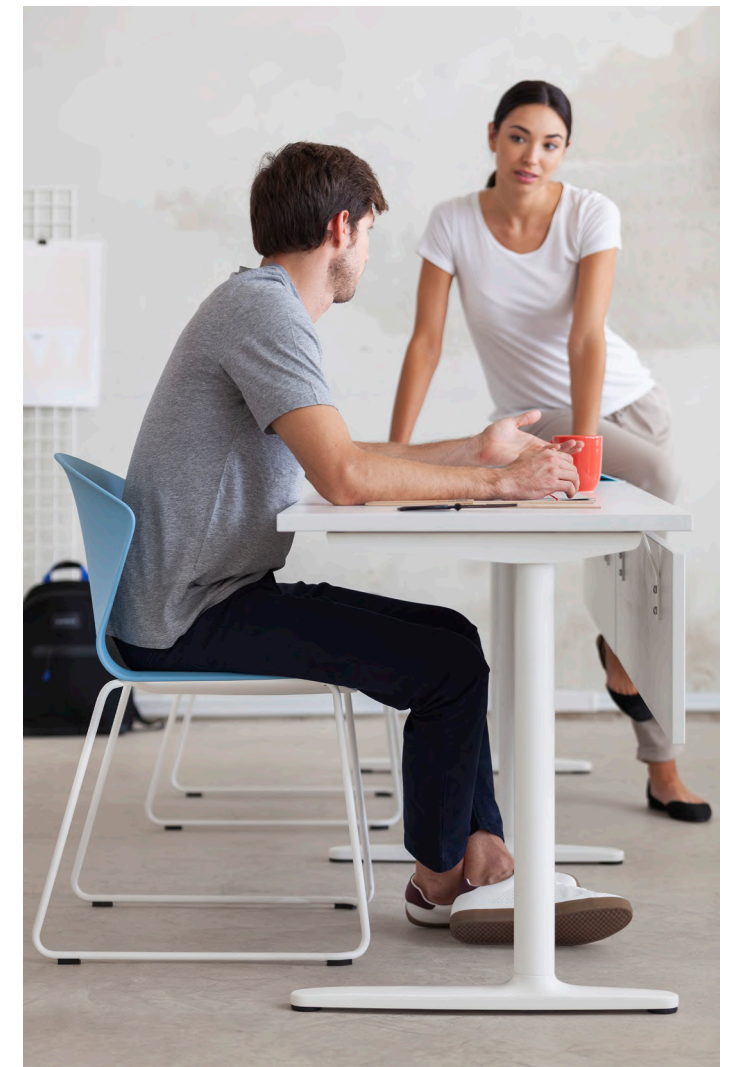
They are fixed and compact tables which are 74 cm high, with a melamine surface and a steel and aluminium structure. They can be complemented with cable access grommets, flaps and have anti-slip levellers to prevent vibrations.



El modelo Talent 100 es perfecta para espacios de formación y centros educativos. Son mesas fijas y compactas de 74 cm de altura, con superficie de melamina y estructura de acero y aluminio. Se pueden complementar con acceso de cableado, faldones y cuenta con niveladores antideslizantes para evitar vibraciones

Le modèle Talent 100 est idéal pour les espaces de formation et des centres d'enseignement. Ce sont des tables fixes et compactes d'une hauteur de 74 cm et d'une surface en mélamine, avec une structure en acier et aluminium. Elle peuvent être complétées à l'aide d'accessoires de câblage et de voiles de fond, et possède des niveleurs antidérapants pour éviter les vibrations.

Talent 100 ist ideal für Seminarräume und Bildungszentren. Es handelt sich um feste und kompakte Tische mit einer Höhe von 74 cm, mit Melaminoberfläche und Stahl- und Aluminiumstruktur. Sie können durch Kabelzugang, Schürzen und rutschfeste Nivellier Vorrichtungen ergänzt werden, um Vibrationen zu vermeiden.



TALENT SERIES

The program is structured around two areas: The Series 500 for office training areas and the Series 300 and 100 for multiuse spaces. For office and operational positions, the Series 500 has high-standing tables with an aluminium base, on wheels with adjustable height and even a large model with a height of up to 138cm

Este programa se estructura en torno a dos ámbitos: uno para las zonas formativas dispuestas en oficinas con la serie 500 y otro para espacios multiusos con la Serie 300 y 100. Para oficina y puestos operativos, la Serie 500 cuenta con mesas de pie central sobre base de aluminio, ruedas, regulación en altura e incluso el gran formato, con un modelo de hasta 138cm.

Ce programme est structuré autour de deux cadres : l'un pour les zones de formation disposées en bureaux avec la Série 500, et l'autre pour les espaces multifonctions avec la Série 300 et la Série 100. Pour les bureaux et les postes de travail, la Série 500 possède des tables avec un pied central sur une base en aluminium, des roulettes, un réglage en hauteur et même un grand format avec un modèle pouvant atteindre 138 cm.

Dieses Programm gliedert sich in zwei Schwerpunkte: einen für die in Büros mit der 500er Serie angeordneten Seminarbereiche und einen für Mehrzweckräume mit der 300er und 100er Serie, für Büros und Bedienstände verfügt die 500er Serie über zentrale Stehtische auf Aluminiumsockel, Rollen, höhenverstellbar und sogar das Großformat mit einem Modell von bis zu 138 cm.

TECHNICAL FEATURES

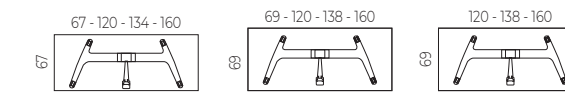
Información técnica

- 1 25 mm melamine desk-top with straight PVC edge.
Superficie de Melamina de 25 mm con canto recto de PVC.
- 2 25 mm melamine desk-top with PVC bumper edge.
Superficie de Melamina de 25 mm con canto redondeado de PVC y goma amortiguante.
- 3 Folding desk top with locking/unlocking system.
Tablero Abatible con Sistema de bloqueo/desbloqueo
- 4 3 mm folded steel plate bracket with an epoxy paint coating.
Ménsula en chapa de acero plegado de 3mm recubiertos con pintura epoxi.
- 5 70x40 and e=2 steel tube recessed crossbar with bumper edge to safely support the desk top.
Larguero retranqueado en tubo de acero de 70x40 y e=2 mm con tope para apoyo de seguridad del tablero
- 6 Ø60 mm aluminium column with an epoxy paint coating.
Columna de aluminio de Ø60 mm recubiertos con pintura epoxi.
- 7 Ø60 mm aluminium column with an epoxy paint coating and electropolished with polished finish.
Columna de aluminio de Ø60 mm recubiertos con pintura epoxi y electropulido con acabado pulido.
- 8 Straight aluminium injection legs with an epoxy paint coating and polished aluminium finish.
Pies rectos de inyección de aluminio recubiertos con pintura epoxi y acabado en aluminio pulido.
- 9 Ø46mm levellers with non-skid patch.
Niveladores de Ø46mm con soleta antideslizante
- 10 Aluminium injection bracket with an epoxy paint coating.
Ménsula de inyección de aluminio recubiertos con pintura epoxi.
- 11 Injected aluminium corner joint for attaching columns and crossbars.
Codo de unión de columnas y largueros en aluminio inyectado.
- 12 Polypropilene vertical stacking cap.
Embellecedor protector de Polipropileno.
- 13 Elevation system in the desk via a gas lift.
Sistema de elevación de la mesa mediante bomba de gas compensada.
- 14 73x70 and e=2 mm extruded aluminium recessed crossbar, with bumper to safely support the desk top.
Larguero retranqueado de aluminio extruido de 73x70 y e=2 mm, con tope para apoyo de seguridad del tablero.
- 15 Injected aluminium telescopic central column with two 110x80 and 100x70 sections and e=2 mm, featuring gas lift elevation system, with an epoxy paint coating.
Columna central telescópica en aluminio extruido con dos secciones de 110x80 y 100x70 mm y e=2 mm, con elevación mediante cilindro de gas, recubiertos con pintura epoxi.
- 16 Aluminium injection legs with lateral junction, with an epoxy paint coating and polished aluminium finish.
Pies con entronque lateral, de inyección de aluminio recubiertos con pintura epoxi y acabado en aluminio pulido.
- 17 Stacking protection on the legs.
Protección de apilamiento en pies.
- 18 65 mm diameter black wheels. 2 with brakes and 2 without brakes.
Ruedas negras de 65 mm de diámetro. 2 con freno y 2 sin freno.

SERIE 500

Height adjustable desks with castors and folding desk-top

Straight desks Mesas rectas



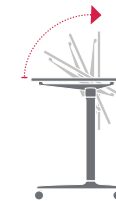
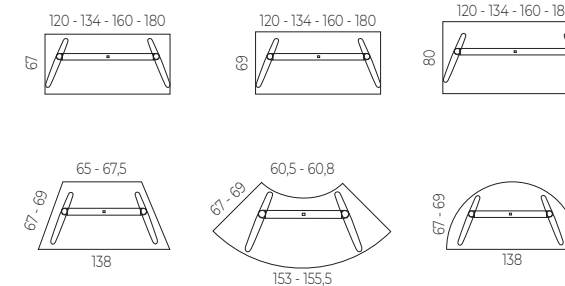
- * Dry erase surface (optional)
- * Superficie de borrado en seco (opcional)



SERIE 300

Fixed desks with castors and folding desk-top

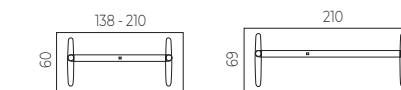
Straight desks Mesas rectas



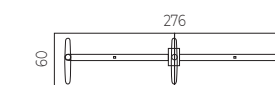
SERIE 100

Fixed desks with levellers

Straight desks Mesas rectas



Straight progressive desks Mesas rectas de progresión



- * Possibility of adding modesty panel, cable tray and screen (optional)
- * Posibilidad de Faldón, Canal de electrificación y divisoria (opcional)

Talent

by Alegre Design

Talent was created to consolidate a single solution that met all the arising needs in spaces that aim to motivate critical thinking, innovation and the transfer of knowledge in a much more active, fun and creative way.

The program is structured around two areas: The Talent Series 500 for office training areas and the Talent Series 300 and 100 for multiuse spaces. For office and operational positions, the Talent Series 500 has high-standing tables with an aluminium base, on castors with adjustable height and even a large model with a height of up to 138cm.

Technical data

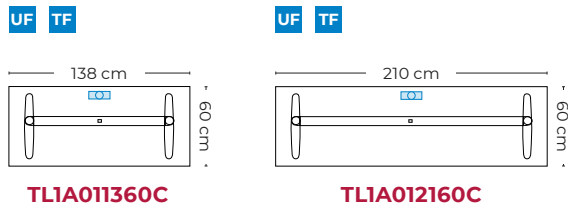
Table program	3
Talent Series 100 · Features, functionalities & Accessories	4
Talent Series 300 · Features, functionalities & Accessories	5
Joining system · Talent Series 100 & 300	6
Talent Series 500 · Features, functionalities & Accessories	7
Finishes available	8
Access to wiring & connections	9
Packs, weights & volumes	10
Ecodesign	10
Regulations & EPD	10
Certificates	10



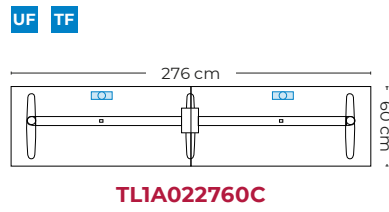
Table program

Talent 100 · Fixed desks with levelers

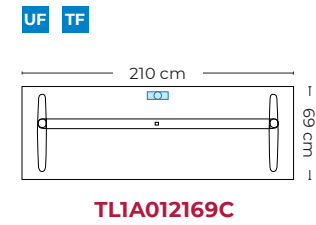
Straight desks · Width 60 cm



Straight progressive tables · Width 60 cm

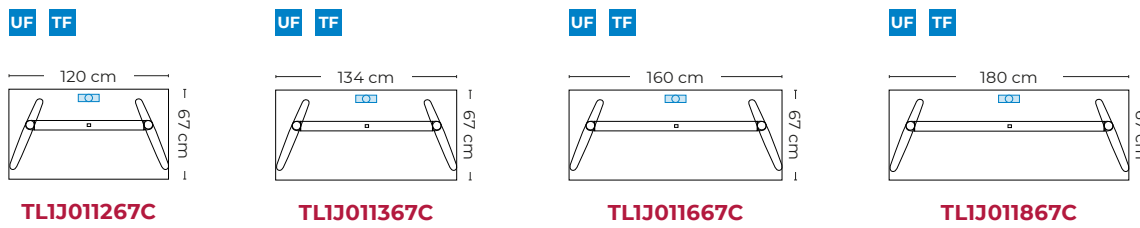


Straight desks · Width 69 cm

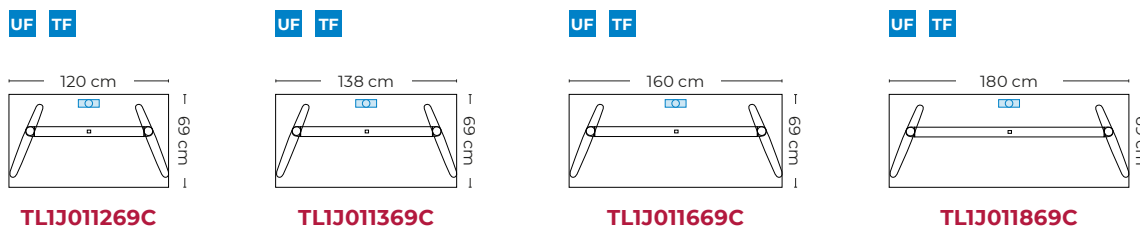


Talent 300 · Fixed desks with castors and folding desk-top

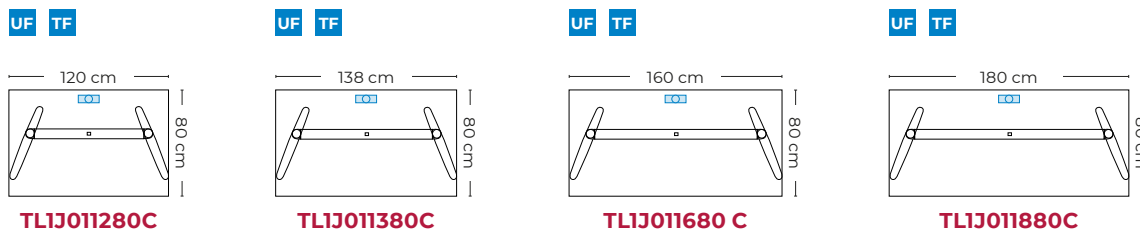
Straight desks · Width 67 cm



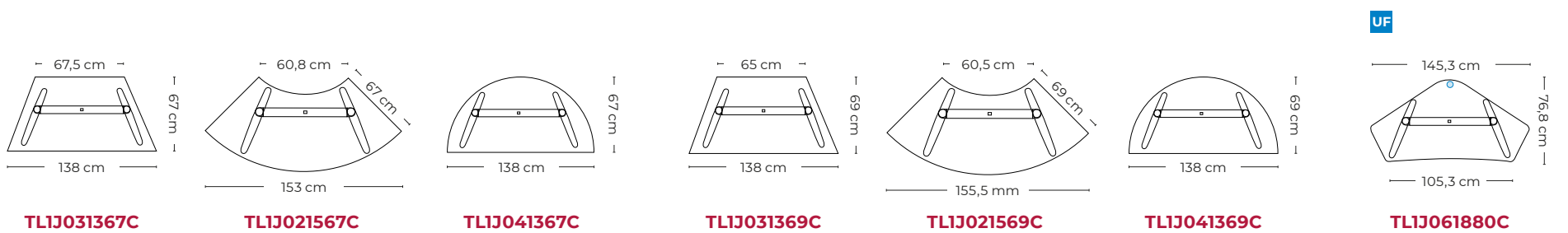
Straight desks · Width 69 cm



Straight desks · Width 80 cm

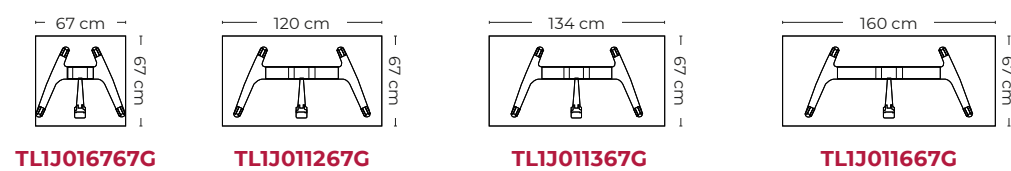


Collectivity desks · Width 67, 69 y 80 cm

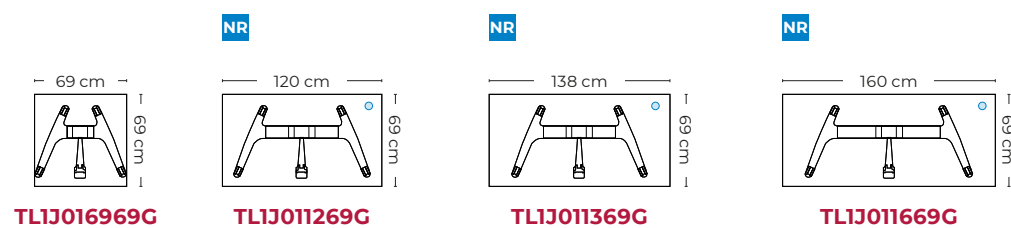


Talent 500 · Lift-up tables with castors & folding desk-top

Straight desks · Width 67 cm



Straight desks · Width 69 cm



Talent Series 100 · Features, functionalities and add-ons



- 1** 25 mm Melamine surface with PVC straight edge.
- 2** Bracket in 3mm folded steel sheet in white and black finish with an epoxy paint coating.
- 3** 70x40 and e=2 mm steel tube recessed beam with stop for safety support of the deck.
- 4** Extruded aluminum column Ø60 mm in white and black finish with an epoxy paint coating.
- 5** Straight injection-molded aluminum feet in white and black finish coated with epoxy paint.
- 6** Ø46mm levelers with non-skid patch.

Accessories

Cable management



Ø80mm "U" wiring access.



Push Latch "T" wiring access.



Metallic tray for access to "T" wiring.



Individual high-capacity metal cable tray.



Flexible polypropylene cable riser.

Desk top screens



Talent offers a variety of options in partitions. Fully upholstered, with aluminum profiles or guides for fixing 3rd level elements, melamine, glass or methacrylate.

Modesty panel



Melamine or veneer skirt.

CPU support



Metal bracket anchored to the beam

Linking of desks



Anchoring by means of plastic clamp e=4mm

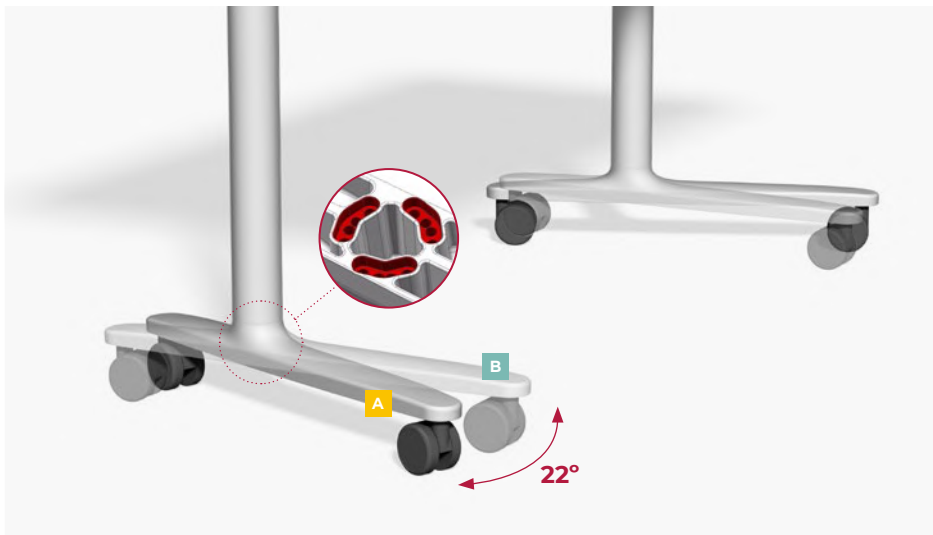
Talent Series 300 · Features, functionalities and add-ons



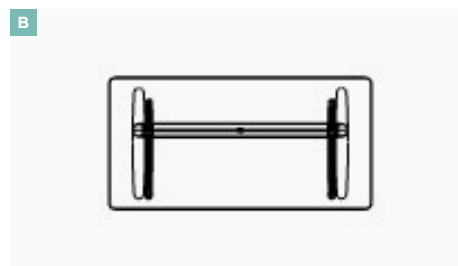
- 1** 25 mm melamine surface with PVC edge and rubber cushioning.
- 2** Folding desk top with locking/unlocking system.
- 3** Aluminum injection bracket in white and black finish with an epoxy paint coating.
- 4** Elbow for joining columns and beams in die-cast aluminum.
- 5** Polypropylene protective trim.
- 6** 73x70 and e=2 mm extruded aluminum recessed beam, with stop for safety support of the deck.
- 7** Extruded aluminum column Ø60 mm in white and black epoxy coated finish.
- 8** Aluminum injection molded feet in white and black finish coated with epoxy paint.
- 9** Stacking protection on feet.
- 10** Black castors of 65 mm diameter. 2 with brake and 2 without brake.

Placement of feet in angular position

The 300 series is offered as standard with a 22° inclined foot. This series offers the possibility to change the feet to a straight foot version by unscrewing the foot and placing the screws in the indicated position.



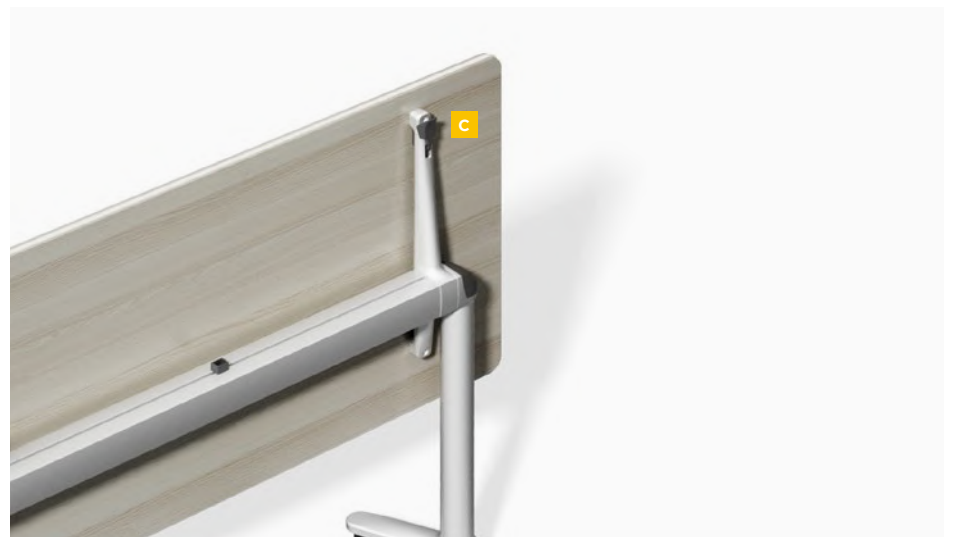
Foot placement at 22 degrees



Placement of the feet in an upright position

Board surface tiltability

The 300 series offers a folding system of the work surface, by means of a system in the brackets, with unlocking and locking position of the mechanism. At the same time, this folding system allows the tables to be stacked in a space-saving manner. The tables are equipped with a stacking protector at the feet.



Locking/unlocking system of the work surface folding in 2 positions.



Hinged skirt anchored to melamine-finished board.

Accessories

Cable management



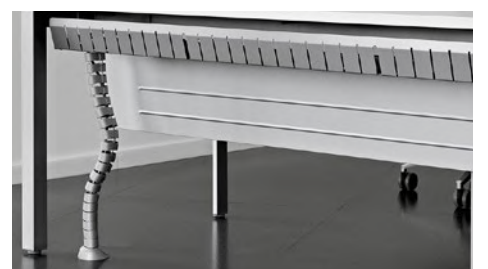
Ø80mm "U" wiring access.



Push Latch "T" wiring access.



Metallic tray with access to "T" wiring.



Flexible polypropylene cable riser.

Folding modesty panel



Melamine skirt

Linking of desks



Quick linking. The desks are prepared to be linked laterally and frontally. They are fixed using a e=4mm plastic bracket

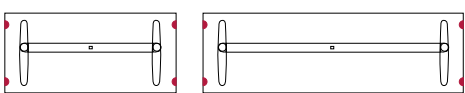
Jointing system · Talent Series 100 & 300

Talent, in its 100 and 300 series, allows a fast system of Linking of desks, so that different configurations can be made, achieving that the tables have stability and there are no undesired movements in their use. The tables are prepared to be joined laterally and frontally, by means of a plastic clamp of e= 4mm, which has a fast and simple system of union.

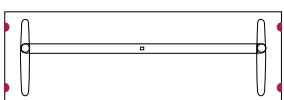


Table models with connecting systems

Talent Series 100 · Fixed desks with levelers · Side connection

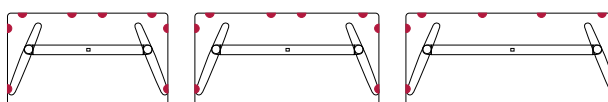


60 cm wide Straight desks

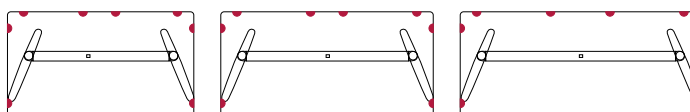


69 cm wide Straight desks

Talent Series 300 · Fixed desks with castors and hinged top · Side and front connection

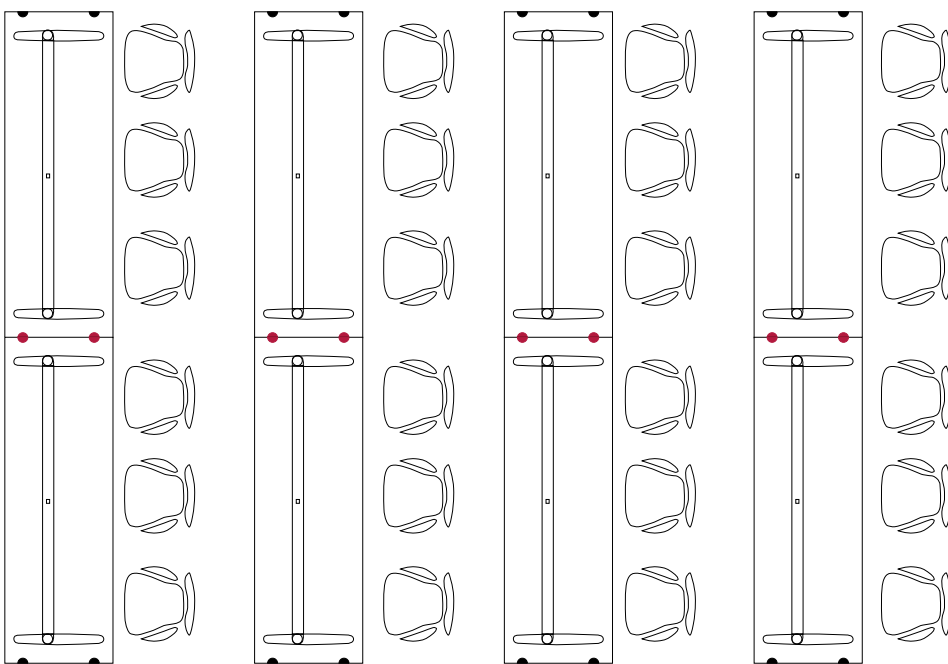


67 and 69 cm wide Straight desks

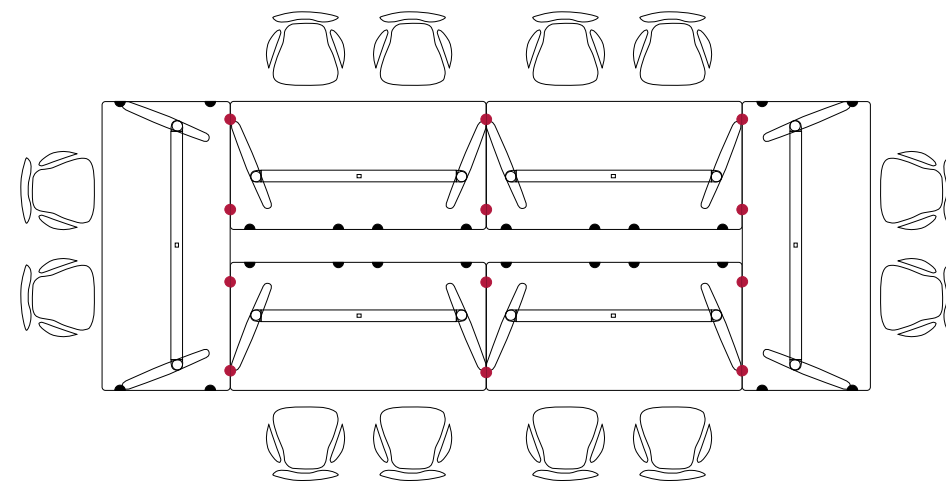


80 cm wide Straight desks

Configuration examples



Lateral joints



Side and front connections

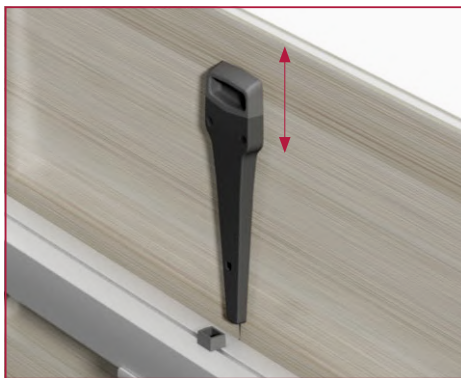
Talent Series 500 · Features, functionalities and add-ons



- 1 25 mm melamine surface with PVC edge and rubber cushioning.
- 2 Folding desk top with locking/unlocking system.
- 3 Aluminum injection bracket in white and black finish with an epoxy paint coating.
- 4 Elbow for joining columns and beams in die-cast aluminum.
- 5 Polypropylene protective trim.
- 6 Table lifting system by means of a compensated gas pump.
- 7 73x70 and e=2 mm extruded aluminum recessed beam, with stop for safety support of the deck.
- 8 Telescopic central column in extruded aluminum with two sections of 110x80 and 100x70 mm and e=2 mm, with elevation by gas cylinder, in white and black finish with an epoxy paint coating.
- 9 Feet with lateral connection, made of aluminum injection in white and black finish coated with epoxy paint.
- 10 Stacking protection on feet.
- 11 Black castors of 65 mm diameter. 2 with brake and 2 without brake.

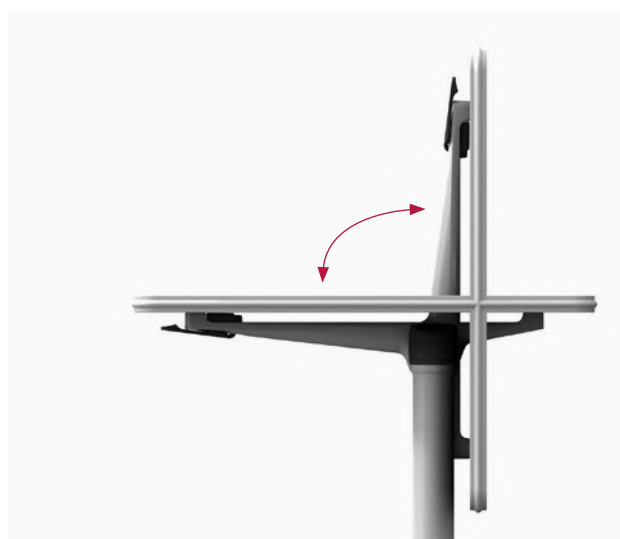
Lifting system

The 500 series has a push button under the table top, easily accessible, which allows the table to be raised by means of a gas pump. Height range: 74-104 cm.



Folding the desk top desk-top

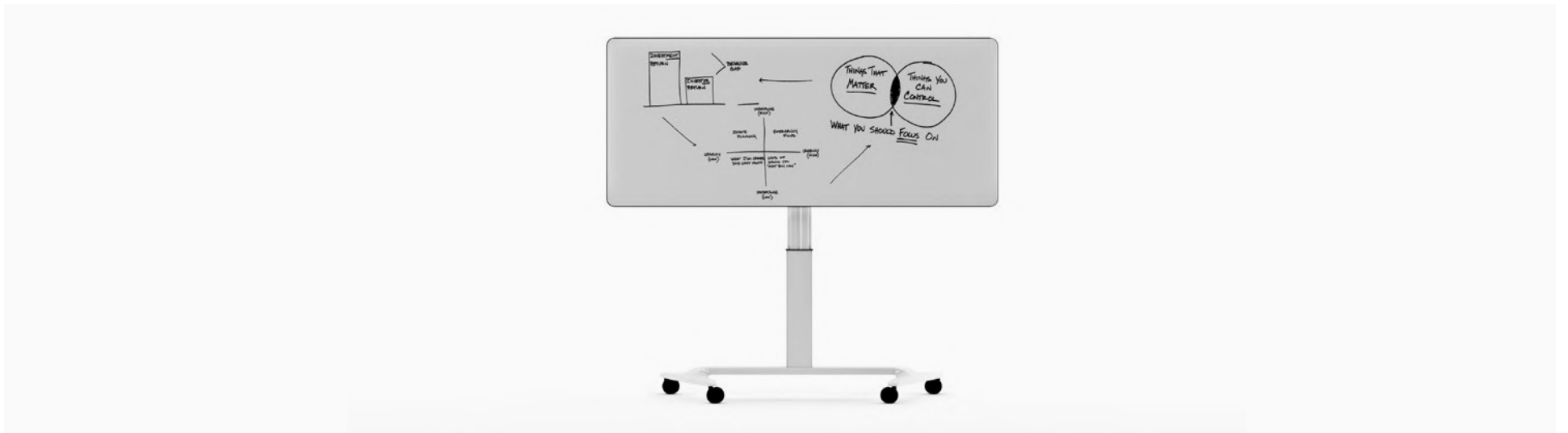
The 500 series offers a folding system of the work surface, by means of a system in the brackets, with unlocking and locking position of the mechanism. At the same time, this folding system allows the tables to be stacked in a space-saving manner. The tables are equipped with a stacking protector at the feet.



Locking/unlocking system of the work surface folding in 2 positions.

Laminated writing surface

24 mm laminated surface with PVC edge and shock-absorbing rubber. Melamine surface laminated in white. For correct writing and long-lasting durability of the table surface, the use of dry-erase markers is recommended. Easy and clean erasure with a simple cloth or eraser, even when the writing has been done for some time. The use of chemical products for cleaning the surface is not recommended.



Talent Desks with connectivity without detracting from mobility



- 1** All models, as standard, incorporate an integrated connection access in the table surface, with a round, flat, minimalist-looking plug integrated into the table. 1 x Schucko + 2 USB charger. Dimensions: Ø10,8 x h:15,3cm.
- 2** Hook made of 3 mm thick steel plate, anchored to the bracket with the capacity to collect the wiring in a simple and clean way.
- 3** Metallic wiring riser, made of 0.8 mm thick steel plate anchored to the column without reducing mobility (elevation), which allows easy cable routing, providing visual cleanliness.
- 4** Built-in 3m long cable wrapped in a textile wiring harness, with zipper system, with additional protection against flame and abrasion.

8



Finishes available

Surface





Structure



Access to cabling and connections

How to order tables with overhead wiring access

WIRING ACCESS U	WIRING ACCESS T
	
<p>Polypropylene cover with a diameter of 80 mm for the passage of wiring to the lower part. The upper part incorporates a small flange for the passage of small wiring and allows the complete cover to be removed for the passage of a large amount of wiring.</p> <ul style="list-style-type: none"> - To request a table with higher access to wiring must be added: <ul style="list-style-type: none"> · Access wiring U: the letter U at the end of the requested reference. - The models that incorporate these accesses in a standardized manner show the corresponding icon or icons next to their reference. - The price of the tables with WIRING ACCESS will be increased for each unit incorporated, according to the price indicated in the table below.. - To order other tables with access to wiring that do not have standardized outlets (they will not contain any icon), consult with the sales department. 	<p>Wiring access system with "Push Latch" opening system. Made of ABS. Incorporates "Anti-Dust" system that avoids dust accumulation in the wiring area..</p> <ul style="list-style-type: none"> - To request a table with higher access to wiring must be added: <ul style="list-style-type: none"> · Access wiring U: the letter U at the end of the requested reference. - The models that incorporate these accesses in a standardized manner show the corresponding icon or icons next to their reference. - The price of the tables with WIRING ACCESS will be increased for each unit incorporated, according to the price indicated in the table below.. - To order other tables with access to wiring that do not have standardized outlets (they will not contain any icon), consult with the sales department.

Surface / structure combinations

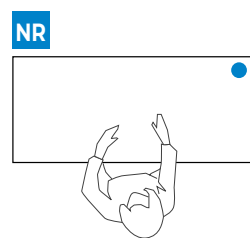
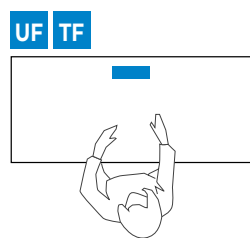
Surface / Structure combinations	WIRING ACCESS T U		
	White	Aluminized	Black
Surface: White Structure: Any finish			
Surface: Any finish (less white) Structure: White			
Surface: Any finish (less white) Structure: Black			

Superior cable access location to cabling and connections

Rectangular desks - 60, 67,69 and 80 cm wide

Front access

Right access



Packs, weights & volumes

Model	Packs	Weights	Volumes
Talent · Series 100	-	-	-
Talent · Series 300	-	-	-
Talent · Series 500	-	-	-

Ecodesign

	Talent · Series 100	Talent · Series 300	Talent · Series 500
Recycled materials	67,24%	69,87%	62,99%
Production	100%		
Transportation	100%		
Use	Easy		
Disposal	91,83%	97,89%	91,32%

Recycled materials: Maximum use of materials to eliminate waste and minimize residues. Use of recyclable materials and recycled materials in components that do not affect functionality and durability. **Production:** Maximum optimization of energy use. Minimum environmental impact. State-of-the-art technological systems. Zero wastewater discharge. VOC-free coatings. Processes free of heavy metals, phosphates, OC and COD. **Transport:** Dismountable systems. Volumes that facilitate space optimization. Maximum reduction of energy consumption for transport. **Use:** Quality and guarantee. Long useful life. Possibility of substitution and replacement of elements. **Disposal:** Waste reduction. Reuse system of supplier-manufacturer packaging. Easy separation of components. Solvent-free water-based printing inks on packaging.

Regulations & EPD

Talent has passed the tests carried out in our laboratory and the tests performed at the Instituto Tecnológico del Mueble (AIDIMA) corresponding to the standards:

Regulations	Description	
UNE - EN 527 - 1:2011	Office furniture. Work tables. Parte 1: Dimensions.	Talent 100
UNE - EN 527 - 2:2017 + A1:2019	Office furniture. Work tables. Parte 2: Safety, strength and durability requirements.	Talent 100
UNE-EN 15372:2017	Furniture. Strength, durability and safety. Requirements for non-domestic tables.	Talent 300 Talent 500
CERTIFICACIÓN GS.	Product complies with product safety law with respect to safety and health assurance.	Talent 300 Talent 500

Certificates

The different programs allow points to be obtained in different environmental categories, referring to sustainable plots, materials and resources, efficiency in water, energy and atmosphere, indoor environmental quality, and innovation and design, which are applied to a building in order to obtain LEED certification.



10



ACTIU TECHNOLOGY PARK

DESIGN & ARCHITECTURE

Space management and design
Products. Own patents
Communication

SUSTAINABILITY

Sustainable production
Product. Eco-design
Services, efficient logistics system
Actiu Technology Park, certified LEED®
Platinum

MANUFACTURER

We are manufacturers
Domain raw materials and processes
Technology and Innovation
Standardized and specific solutions

GLOBAL COVERAGE

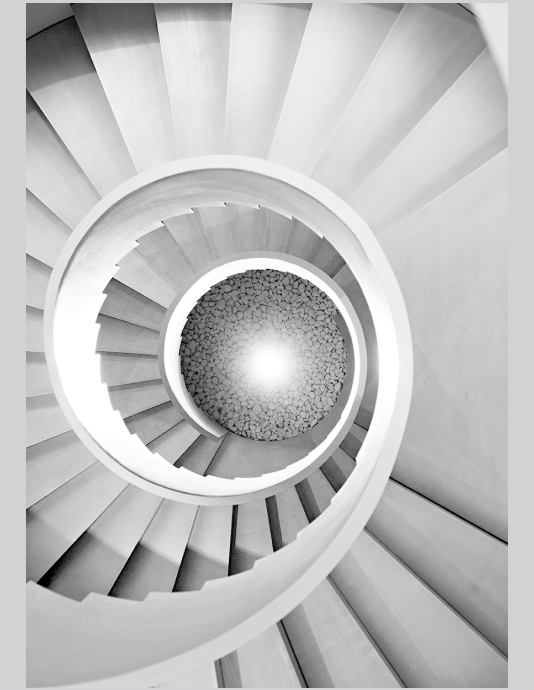
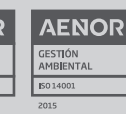
Presence in more than 90 countries
Global equipment solutions. Corporate, Health,
Education, Contract, Transport.

CERTIFICATES AND REFERENCES

ACTIU products fulfill all demands about management, quality and sustainability to provide extra value to the projects using recycled materials to get the recyclable final product.



Actiu, the first industrial company
in the world to obtain the
WELL v2 and LEED Platinum Certification



ACTIU: 50 YEARS DESIGNING PUBLIC SPACES AND WORKSPACES.

Actiu is an industrial company working within the installation sector and specialising in the manufacture of furniture. Actiu's flexibility and productive capacity enable the company to carry out comprehensive equipment projects worldwide, providing solutions that favour the wellbeing of people.

ACTIU, 50 AÑOS DISEÑANDO ESPACIOS PÚBLICOS Y DE TRABAJO.

Actiu es una empresa con una trayectoria industrial en el sector de la instalación, especializada en la creación de mobiliario, cuya flexibilidad y capacidad productiva permite desarrollar proyectos de equipamiento global a nivel internacional aportando soluciones que ofrezcan el bienestar de las personas.

ACTIU, 50 ANS DE CONCEPTION D'ESPACES PUBLICS ET DE TRAVAIL.

Actiu est une entreprise dotée d'un parcours à caractère industriel dans le secteur de l'installation, qui se spécialise dans la création de mobilier, et dont la flexibilité et la capacité de production permettent de développer des projets d'équipement global à un niveau international, tout en apportant des solutions qui puissent offrir du bien-être aux personnes.

ACTIU, 50 JAHRE DESIGN UND PRODUKTION VON MÖBELN FÜR ÖFFENTLICHE EINRICHTUNGEN UND ARBEITSRÄUME.

Unsere ständige Forschung, Weiterentwicklung, Flexibilität und Erfahrung ermöglichen es uns, Projekte im privaten und öffentlichen Bereich der verschiedensten Sektoren auf nationaler und internationaler Ebene durchzuführen. Stillstand ist uns fremd. Uns treibt das Bedürfnis an, näher an den Menschen zu sein und Lösungsmöglichkeiten zu entwickeln, die den Endnutzern Wohlgefühl bieten.

ACTIU reserves the right to carry out technical, dimensional and finishing modifications that it considers appropriate with respect to the information detailed in this document, so please check before confirming your orders.

ACTIU se reserva el derecho de llevar a cabo las modificaciones técnicas, dimensionales y de acabados que estime conveniente respecto a la información detallada en este documento, por el que se ruega verificación antes de confirmar sus pedidos.

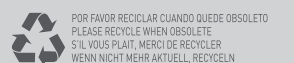
We dream to go beyond our own immediate reality. We design to mature our desires. We walk because only our initiative changes the world and breaks new ground. We move ourselves by being ourselves without the fear of underperforming against our own expectations and goals.

D. Vicente Berbegal Pérez

President and Founder of the Actiu Group.



ACTIU, National Design Award 2017
ACTIU, Premio Nacional de Diseño 2017





www.actiu.com