

# DORIK

Designed by odosdesign

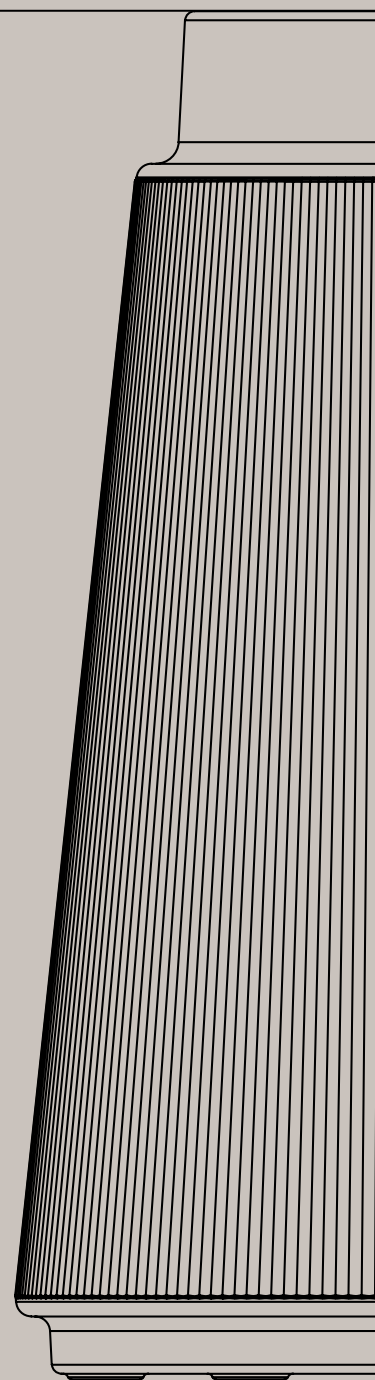

ACTIU

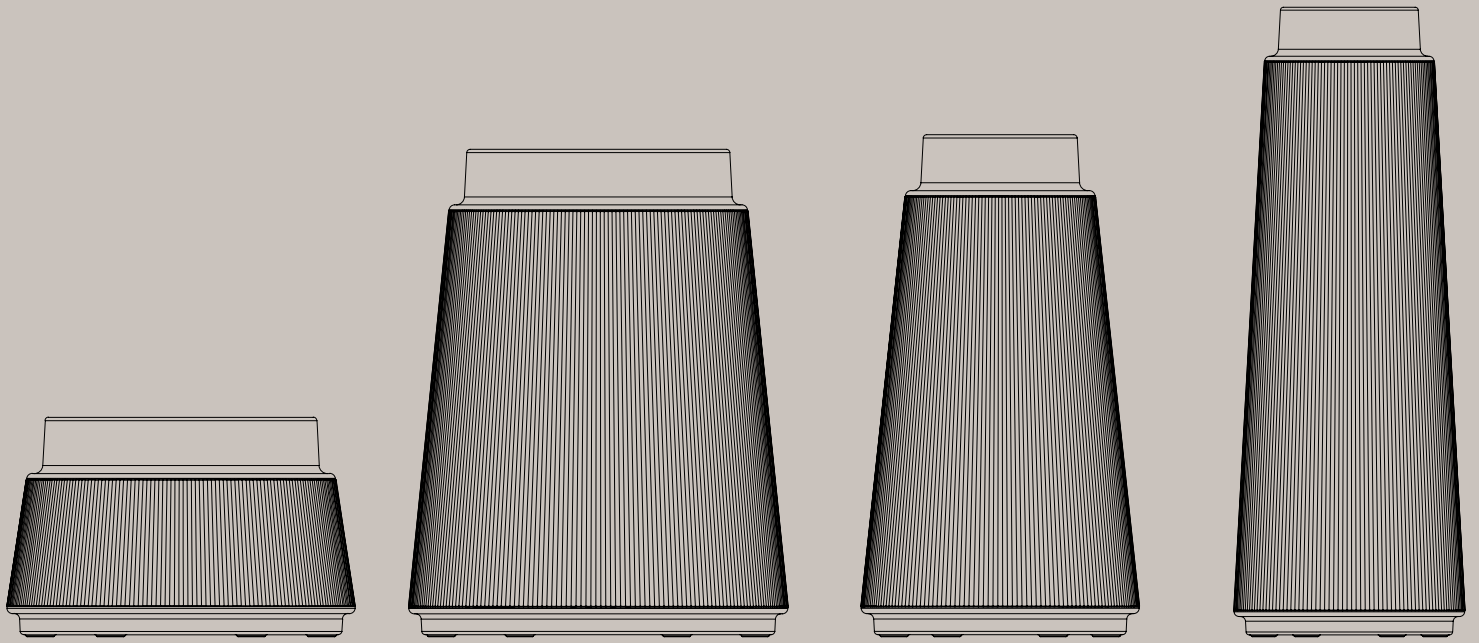

# DORIK

Designed by odosdesign

ACTIU

# INDEX

4	ACTIU
10	LIFEFRIENDLY SPACES
14	DISEÑADOR / DESIGNER
16	COLECCIÓN / COLLECTIONS
52	ESPACIOS / SPACES
64	ACABADOS / FINISHES
68	TÉCNICO / TECHNICAL

# NUESTROS VALORES OUR VALUES

ES  
DISEÑO PARA EL BIENESTAR  
COMPROMISO CON LA  
SOSTENIBILIDAD  
INNOVACIÓN TRANSFORMADORA  
EL VALOR DE LA INDUSTRIA  
PASIÓN POR LO QUE HACEMOS  
EN  
DESIGN FOR WELLBEING  
COMMITMENT TO SUSTAINABILITY  
TRANSFORMATIVE INNOVATION  
THE VALUE OF INDUSTRY  
PASSION FOR WHAT WE DO

PRECISIÓN EN  
EL PROCESO,  
SOSTENIBILIDAD  
EN CADA PASO.

PRECISION IN  
THE PROCESS,  
SUSTAINABILITY  
IN EVERY STEP.

# DESIGN MEETS INDUSTRY

ES Aunque el diseño industrial se enfoca en la funcionalidad y la ergonomía, el componente artístico presente en el bocetaje juega un papel crucial. A través de trazos simples pero cargados de expresividad, el diseñador va jugando con formas, proporciones y detalles para encontrar el equilibrio entre lo estético y lo funcional. Los bocetos ponen al diseñador ante el desafío de descubrir nuevas direcciones estéticas con la necesidad de conservar la viabilidad técnica del diseño.

EN Although industrial design focuses on functionality and ergonomics, the artistic component present in sketching plays a crucial role. Through simple yet expressive strokes, the designer explores shapes, proportions, and details to find a balance between aesthetics and functionality. Sketches challenge the designer to discover new aesthetic directions while maintaining the technical feasibility of the design.



PROCESO DE TRABAJO DEL TABLERO  
BOARD WORKING PROCESS



NAVE 7 - PLANTA DE MADERA  
HALL 7 WOOD PLANT

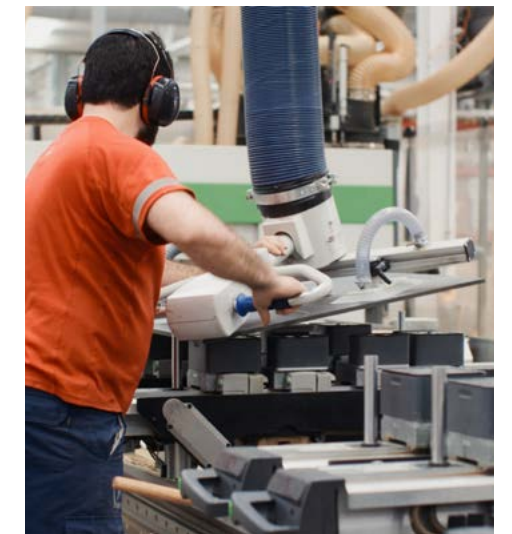

PROCESO DE TRABAJO DEL TABLERO  
BOARD WORKING PROCESS



PROCESO DE TRABAJO DEL TABLERO  
BOARD WORKING PROCESS



PROCESO DE MECANIZADO DEL TABLERO  
BOARD MACHINING PROCESS

ES La experiencia compartida entre el diseñador y la industria que materializa sus diseños es fundamental en el proceso de co-creación. El diseñador, con su visión y creatividad, establece los pilares del proyecto, transmitiendo sus necesidades y objetivos. En paralelo, la industria entra en escena aportando su experiencia técnica y conocimientos productivos.

Esta sinergia permite no solo materializar la visión del diseñador, sino también optimizarla, gracias a la retro-alimentación técnica y la comprensión de los límites y posibilidades industriales.

EN The shared experience between the designer and the industry that brings their designs to life is fundamental in the co-creation process. The designer, with their vision and creativity, establishes the project's foundations, conveying their needs and goals. In parallel, the industry steps in, contributing its technical expertise and production knowledge.

This synergy not only allows the designer's vision to be materialized but also optimizes it, thanks to technical feedback and an understanding of industrial limitations and possibilities.

# ARTE E INDUSTRIA ART AND INDUSTRY



ROTOMOLDEO  
/ ROTOMOULDING

¿Y si pensamos  
los espacios  
*para vivirlos?*



# LIFE *Friendly* SPACES

ES Life Friendly Spaces es un modelo de cultura empresarial asumido por todos los equipos que formamos ACTIU (trabajadores, proveedores y colaboradores) con el bienestar y la salud de las personas, el reconocimiento de la tecnología como facilitadora de la vida que llevamos, una visión diversa e inclusiva en nuestras relaciones y un enfoque holístico de la sostenibilidad, ofreciendo una experiencia regenerativa en los espacios que habitamos y en nuestro entorno. Un enfoque que establece un legado de responsabilidad, eficiencia y respeto hacia el medio ambiente y las futuras generaciones.

EN Life Friendly Spaces is a business culture model embraced by all the teams that make up ACTIU (employees, suppliers, and collaborators), with a focus on the well-being and health of people, the recognition of technology as a facilitator of the life we lead, a diverse and inclusive vision in our relationships, and a holistic approach to sustainability. This offers a regenerative experience in the spaces we inhabit and in our environment. It is an approach that establishes a legacy of responsibility, efficiency, and respect for the environment and future generations.



What if we  
think of spaces  
*for living?*

# 01\_ Espacios de los que *se sale mejor de lo que se entra.*

Spaces where *we prefer to get in rather*  
than to get out of them.

# 02\_ Espacios que *cuidan el entorno.*

Spaces that care about the environment.



# 03\_ Espacios que *se mueven contigo.*

Spaces that *move with you.*

# 04\_ Espacios en los que *apetece encontrarse.*

Spaces *where you feel like* meeting up.



# 05\_ Espacios en los que *quepamos todos.*

Spaces *where we can all fit together.*

# 06\_ Espacios que *respetan* *tu propio espacio.*

Spaces that *respect your own* space.

# 07\_ Espacios en los que *florece.*

Spaces in which to *flourish.*

# 08\_ Espacios *más humanos* gracias a la tecnología.

*More human* spaces  
thanks to technology.



# ODOSDESIGN

ES “Nosotros damos vida a ideas rompedoras”. Durante más de 21 años, Odosdesign ha acumulado experiencia utilizando la creatividad, la investigación y el diseño transformador para ofrecer los resultados más impactantes y duraderos. Odosdesign se ha dedicado a crear con un objetivo, a través de su experiencia y empuje. Su trabajo es una solución y un compromiso con el objetivo de cultivar una relación a largo plazo con los clientes, dando forma a la industria mediante el uso de la creatividad como una fuerte ventaja para dar forma a las empresas y la cultura del diseño.

EN “We bring breakthrough ideas to life”. For over 21 years, Odosdesign has accumulated experience using creativity, research and transformative design to deliver the most impactful and lasting results. Odosdesign is dedicated to creating with a purpose, through their experience and drive. His work is a solution and a commitment to the goal of cultivating a long-term relationship with clients, shaping the industry by using creativity as a strong advantage to shape business and design culture.

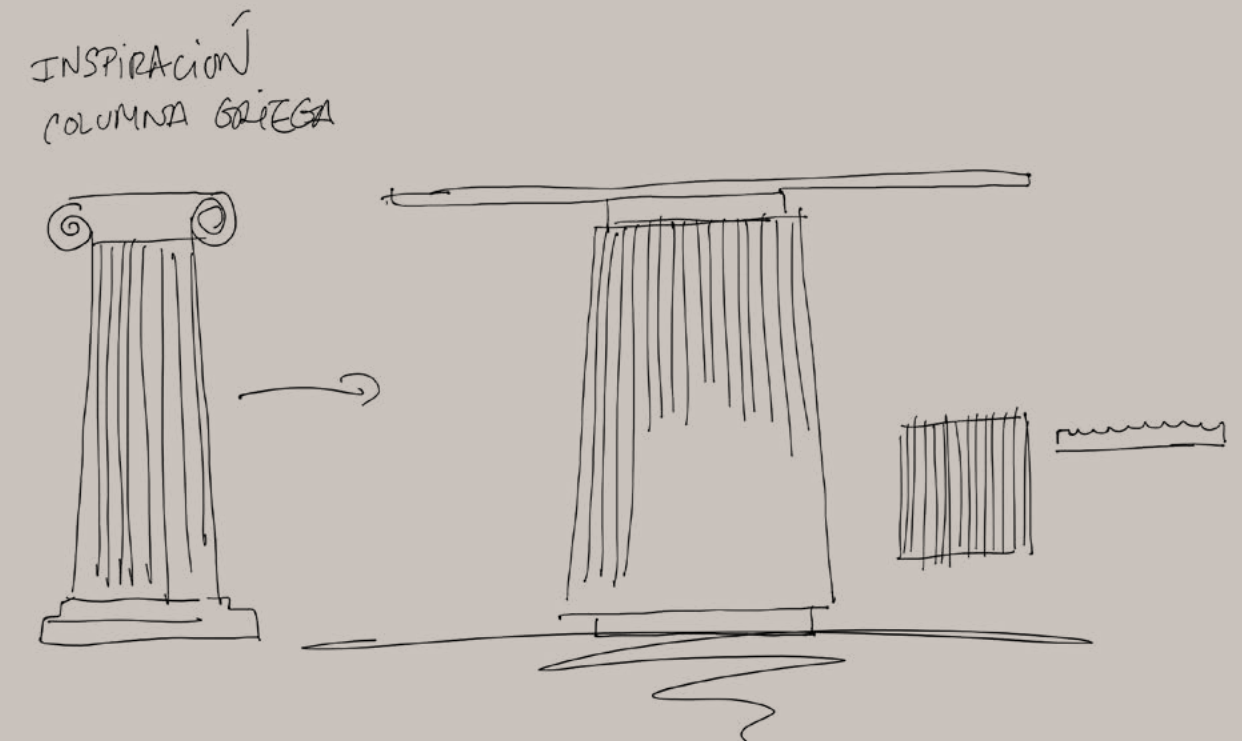

# LA ARMONÍA DE LA ARQUITECTURA GRIEGA. THE HARMONY OF GREEK ARCHITECTURE.

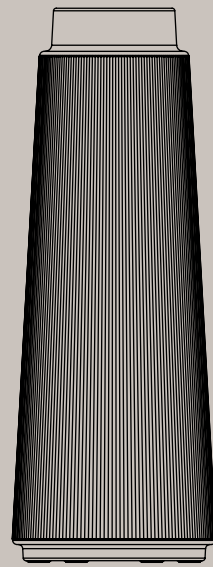

H1028 Ø 370

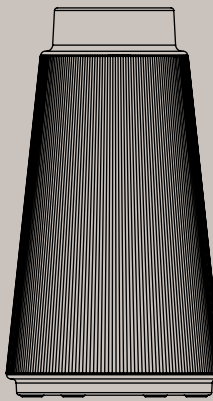

H718 Ø 400

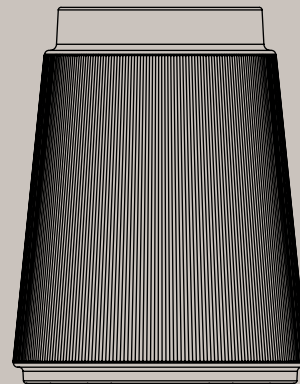

H702 Ø 550

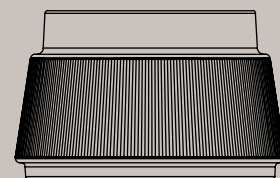

H312 Ø 490

ES Dorik es la colección de mesas inspirada en la grandeza de las columnas clásicas dóricas de la cultura griega. Como en la arquitectura de la Grecia clásica, esta colección de mesas se caracteriza por su elegancia atemporal y su aspecto sencillo pero limpio de proporciones armónicas.

EN Dorik is the table collection inspired by the grandeur of the classical Doric columns of Greek culture. As in classical Greek architecture, this collection of tables is characterized by timeless elegance and a simple yet clean look with harmonious proportions.

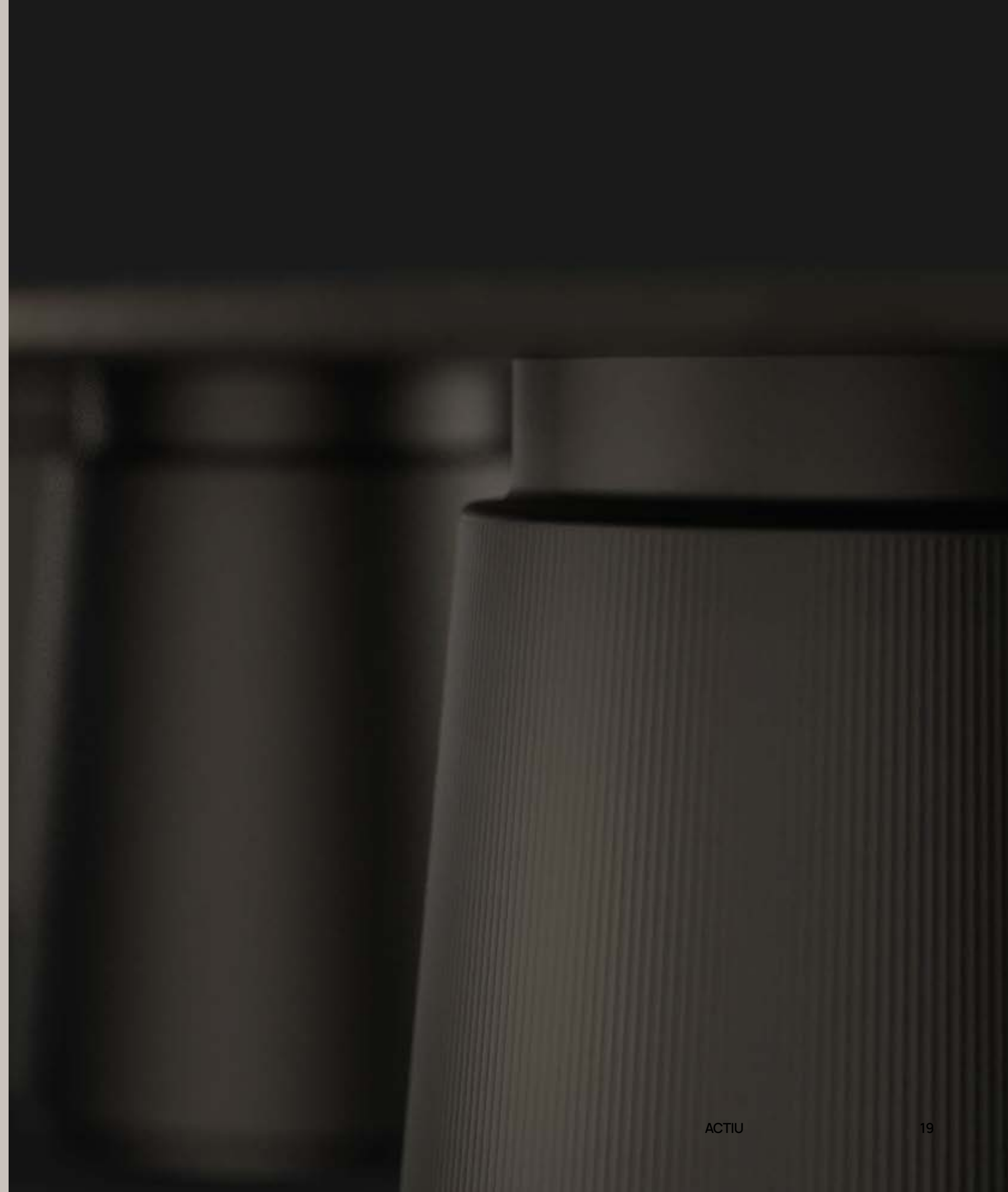

Designed by odosdesign

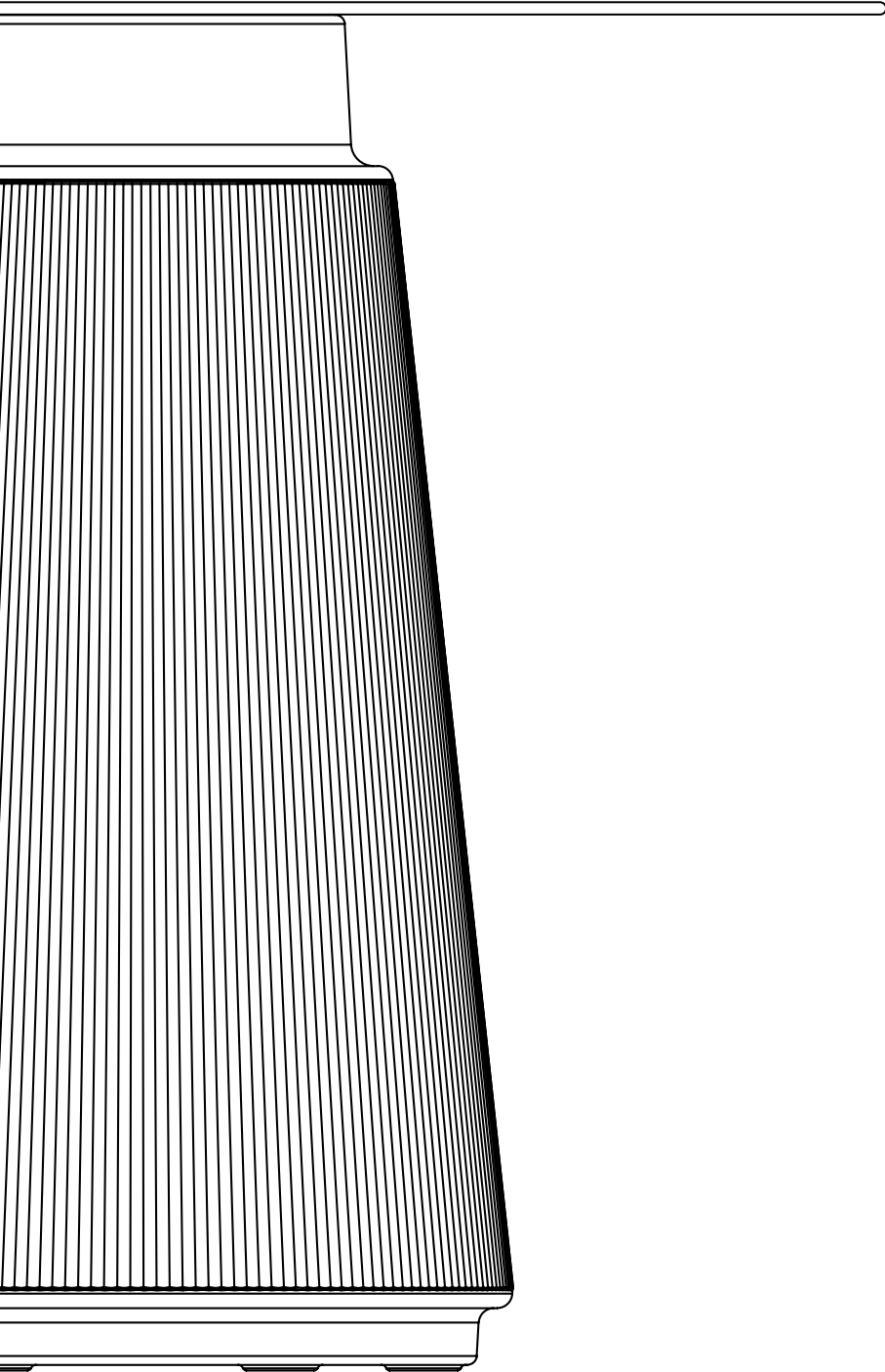

# DORIK

# Tables





UNA VUELTA MÁS A LA  
ELEGANCIA Y ESTABILIDAD  
ESTRUCTURAL

A FURTHER RETURN TO  
ELEGANCE AND  
STRUCTURAL STABILITY





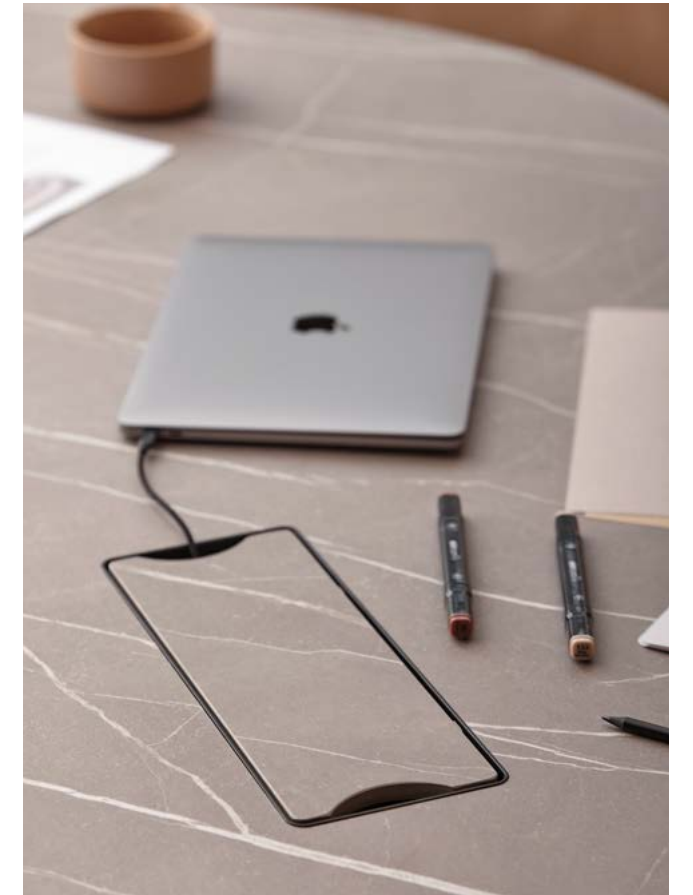

ES Cada mesa está meticulosamente fabricada con una atención excepcional al detalle, exhibiendo la maestría del moldeo rotacional.

EN Each table is meticulously crafted with exceptional attention to detail, showcasing the mastery of rotational molding.









es Dorik ofrece una amplia gama de tamaños, alturas y prestaciones para adaptarse a diversas necesidades. Permite además su expansión con con varias columnas, facilitando la configuración de mesas de reunión.

EN Dorik offers a wide range of sizes, heights and features to suit various needs. It can also be expanded with several columns, facilitating the configuration of meeting tables.





ICÓNICA Y POLIVALENTE.  
ICONIC AND MULTIPURPOSE.







ES Diseño sin fronteras. Una mesa que se adapta a todo, ya sea interior o exterior.

EN Design without borders. A table that adapts to everything, whether indoors or outdoors.



WORKPLACE  
HOSPITALITY  
OUTDOOR

SPACES

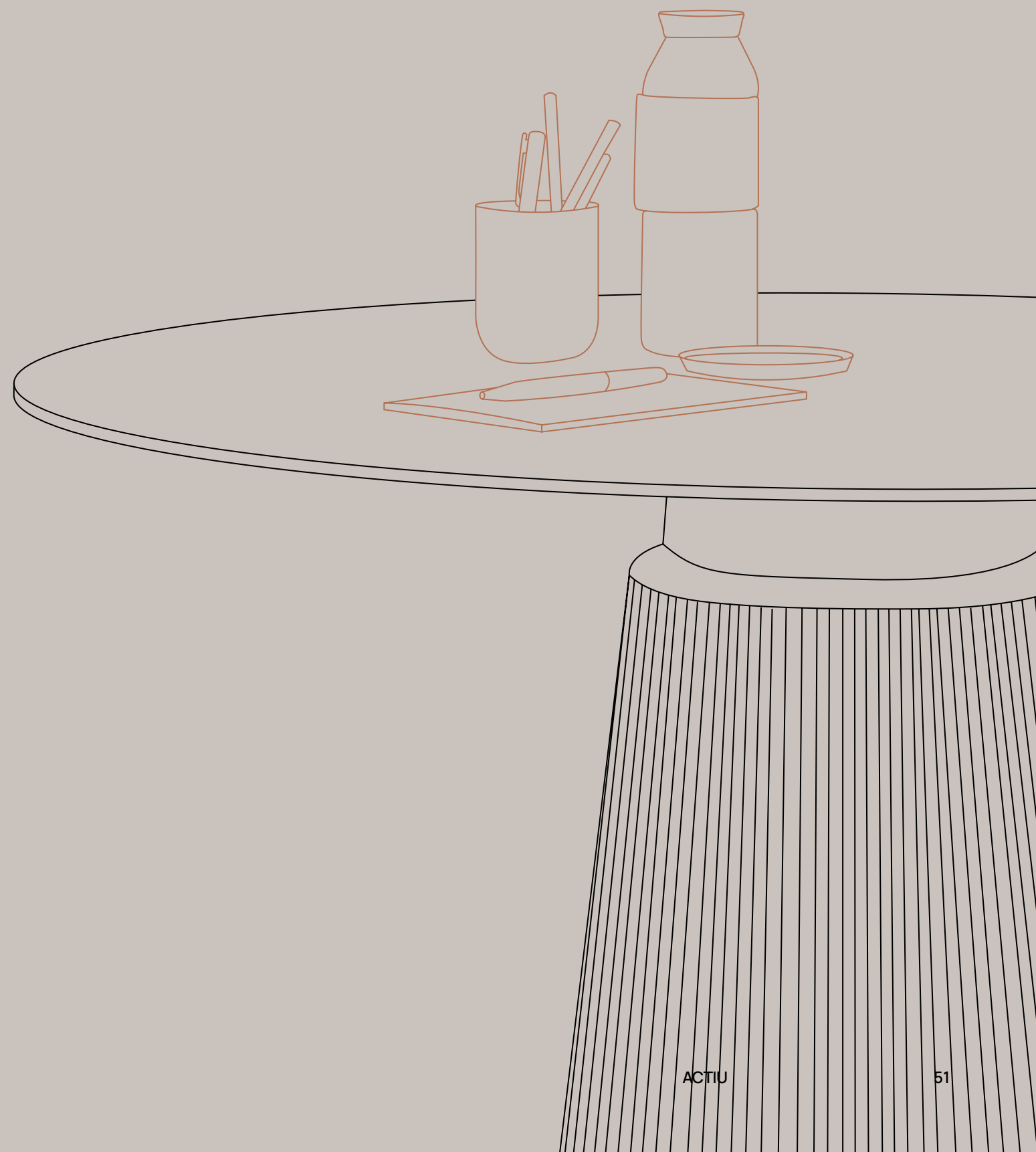

SPACES



ODOSDESIGN STUDIO  
→ Valencia

# WORKPLACE







MARE BEACH RESTAURANT  
→ Calpe

# HOSPITALITY







ALDIMESA CONTRACT  
→ Alicante

# OUTDOOR





# SURFACES

## COMPACT LAMINATE

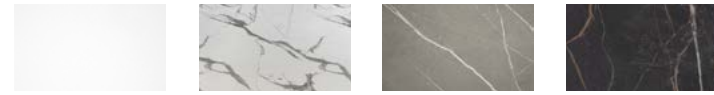
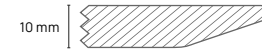

WHITE TRAFIC OLIMPO MARBLE PULPIS LIGHT SAMAS BLACK

## DEKTON® BY COSENTINO

Ultra-compact Engineered Stone Surfaces

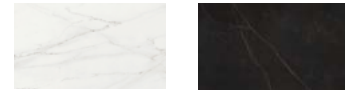

REM WHITE KEYLA BLACK

## MELAMINE



WHITE COCO GREY LIME OAK LIGHT OAK



CHESTNUT DARK OAK BLACK ANTI-FINGERPRINT

## DM

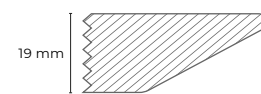

LIGHT OAK

## COLUMN

### POLYETHYLENE

Made with an average thickness of 6 mm

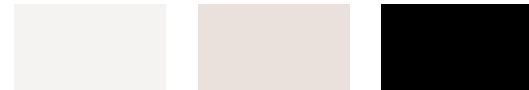

WHITE MINK BLACK

→ Selección de acabados.  
Consultar amplitud de gama  
en oferta Actiu.

Finishes selection. Full range  
available upon request from  
Actiu.

# ACABADOS FINISHES





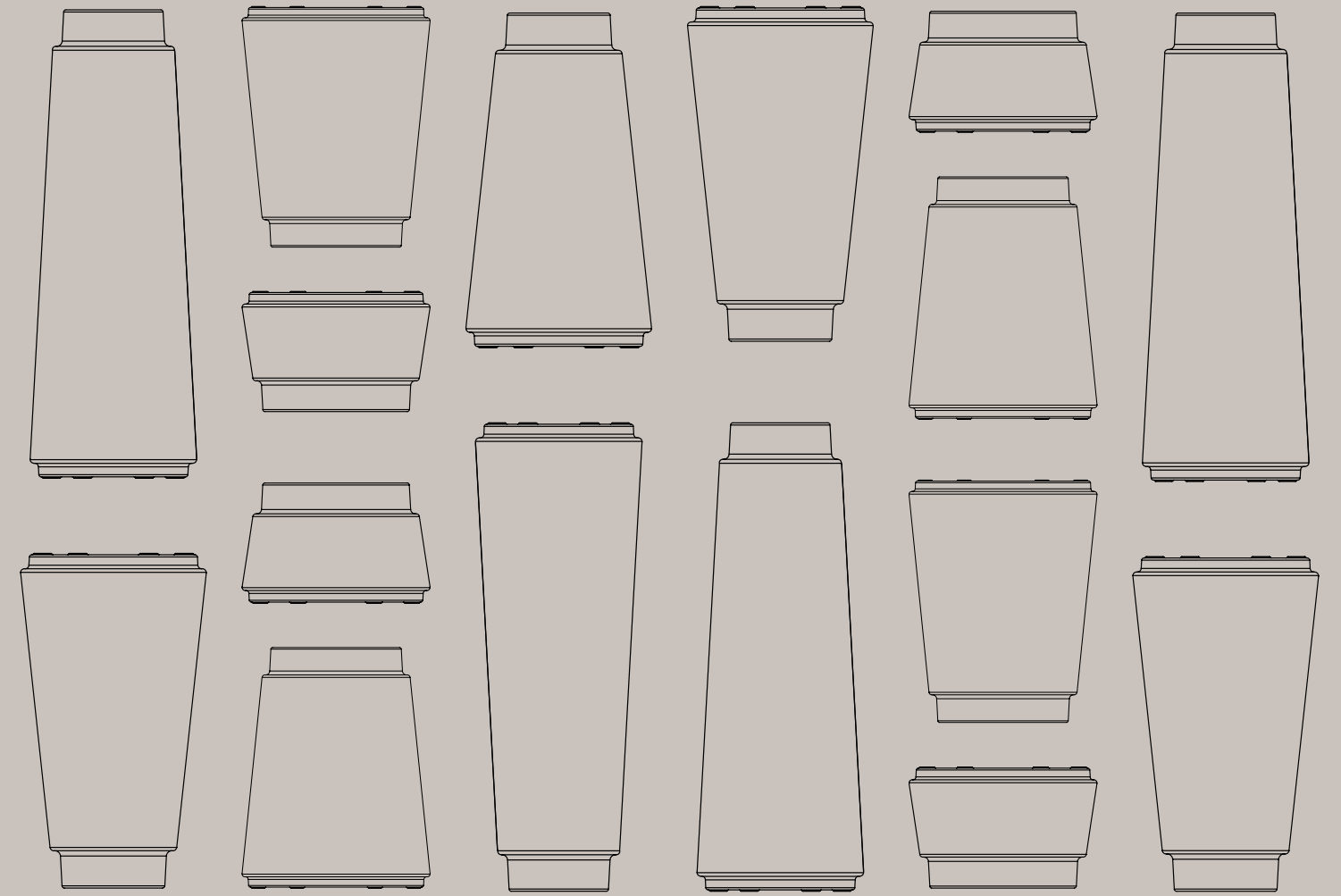

# TÉCNICO

## TECHNICAL

## MESAS CONTRACT/ CONTRACT TABLES

Altura 740mm

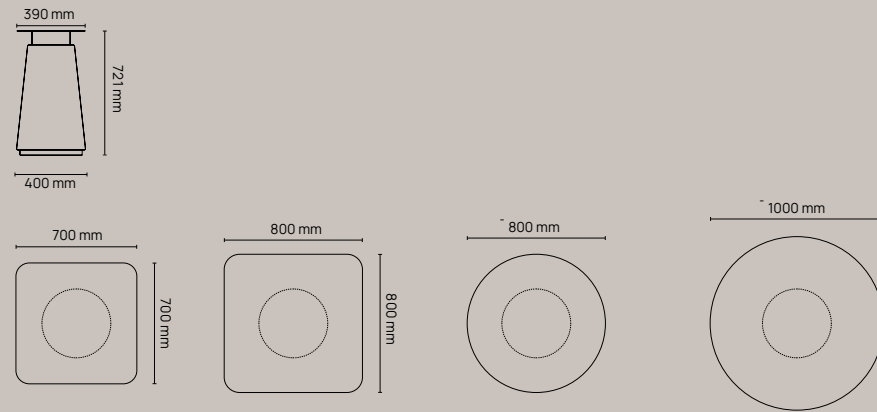

Altura 1050mm

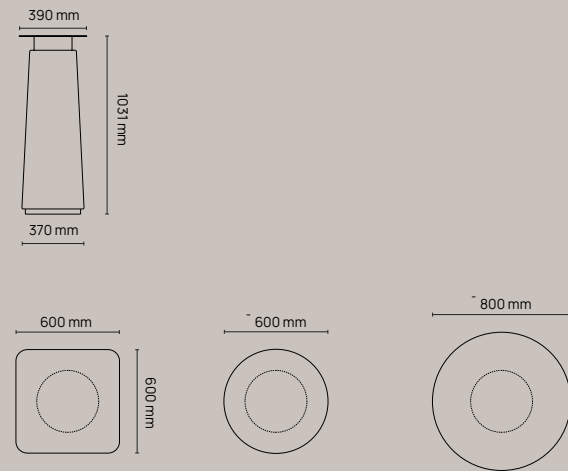

## MESAS CENTRO/ COFFE TABLES

Altura 350mm

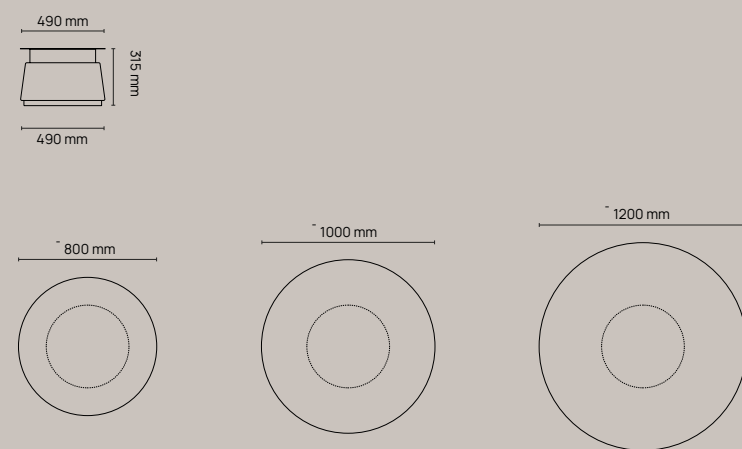

## MESAS REUNIÓN / MEETING TABLES

Altura 1050mm

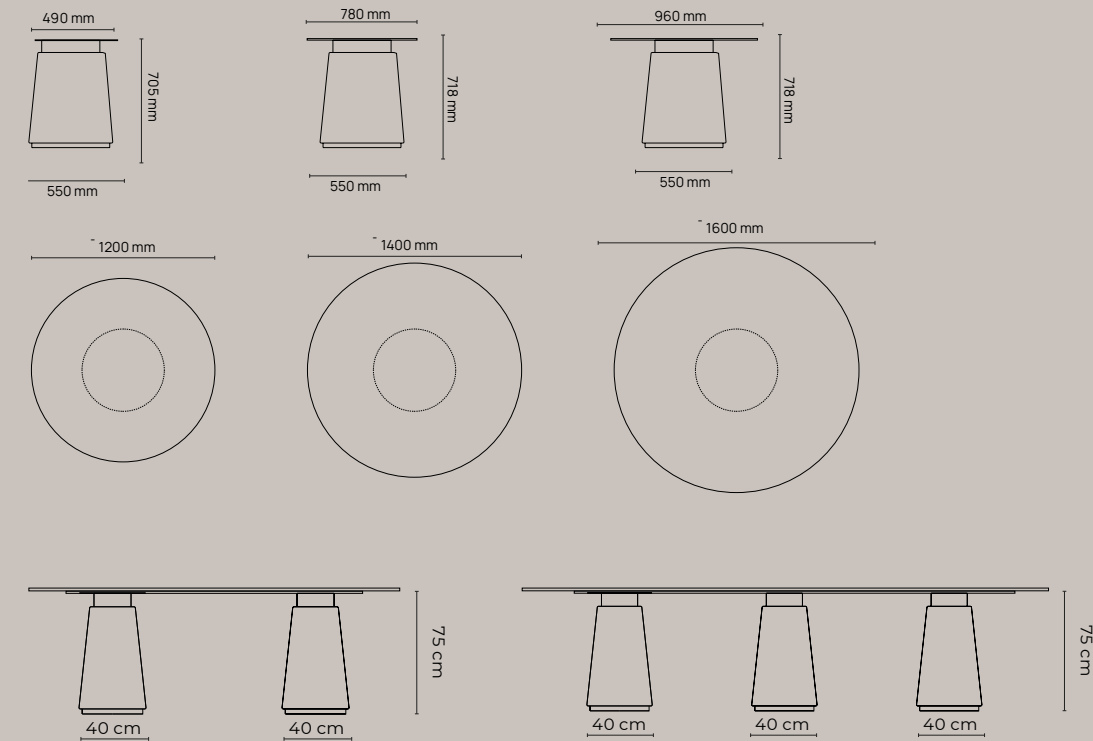

Ancho 1000 mm

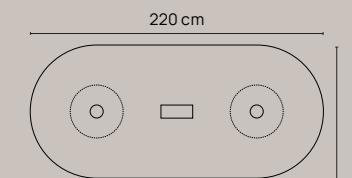

Ancho 1200 mm

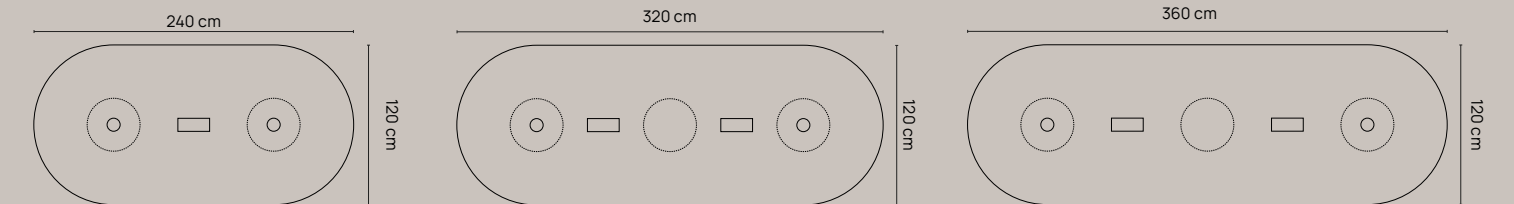

Ancho 1400 mm

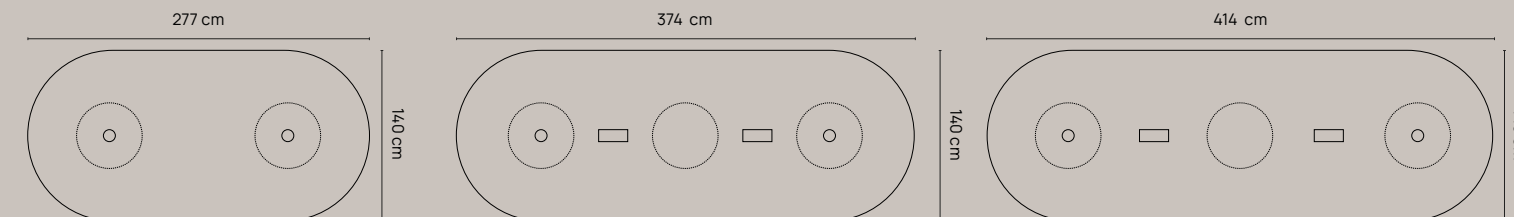

## CABLEADO Y CONEXIONES / WIRING AND CONNECTIONS



Enchufe  
Puerto USB / Puerto tipo C

Plug  
USB port / Type C port



Puerto USB / Puerto tipo C  
USB port / Type C port



Enchufe  
Puerto USB / Puerto tipo C

Plug  
USB port / Type C port



Tapa acceso conexiones  
Puerto USB / Puerto tipo C

Access cover connections  
USB port / Type C port

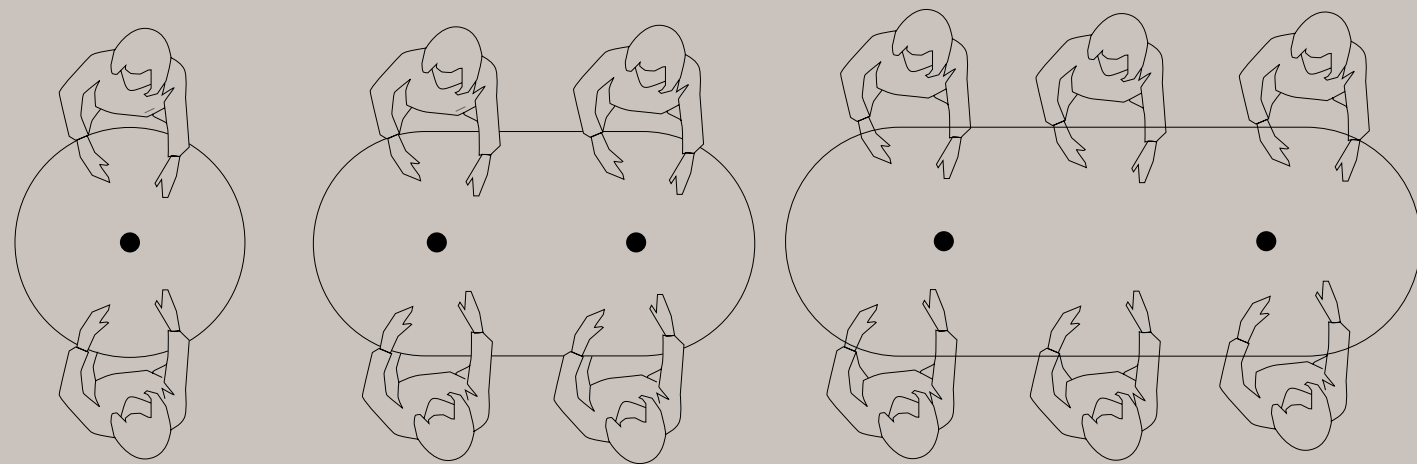

## ACCESORIOS / ACCESSORIES



# Dorik by Odosdesign

## Pillars of Mediterranean design

Undeniably Mediterranean in origin, Dorik finds its inspiration in the grandeur of the classical columns of ancient Greek Doric architecture. Sculpted in harmonious proportions to feature intricate details and refined textures, Dorik tables bring a timeless elegance to any room. Manufactured using the rotational moulding technique, the resulting pieces are able to stand on a single leg, which allows them to be expanded in the use of several columns in order to extend their use, for example to form distinguished meeting tables.

### Technical data

Program of tables	3
Features & functionalities	4
Finishes available	6
Optional complements	7
Packs, weights & volumes	8
Ecodesign	9
Regulations & EPD	9
Certificates	9
Access to wiring and connections	10



Program of tables

Contract tables · Height 74 cm

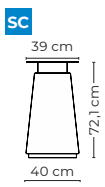

DR1S020040C

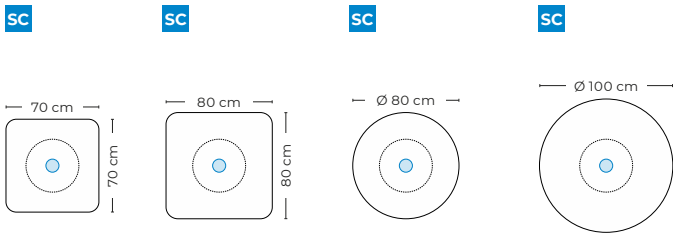

DR1T027070J DR1T028080J DR1T030080J DR1T030100J

Meeting tables · Height 74 cm

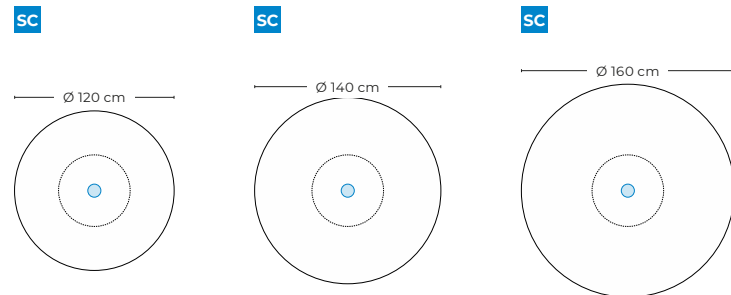
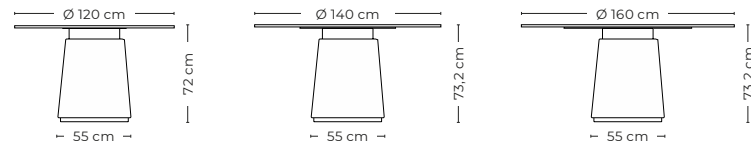

DR1G030120C DR1G030140C DR1G030160C

Meeting tables · Height 74 cm

100 cm width

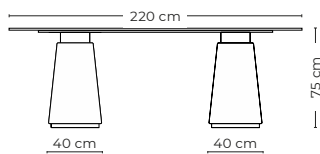

SC QC RC

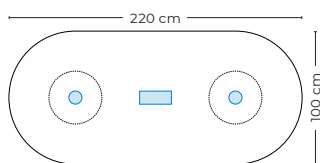

DR1G042210C

120 cm width

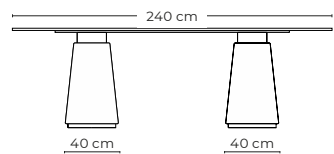

SC QC RC

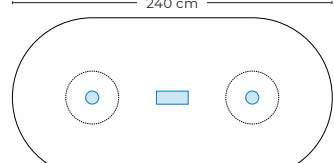

DR1G042412C

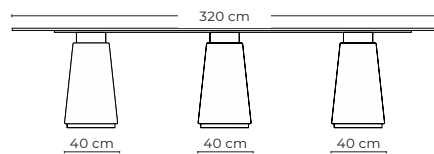

SC QC RC

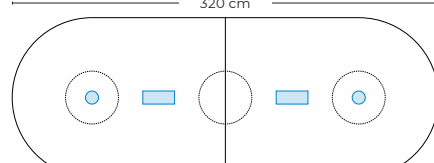

DR1G043212C

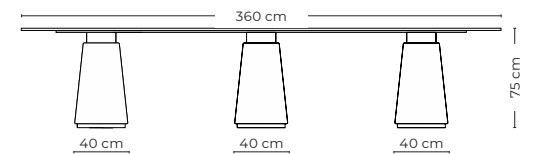

SC QC RC

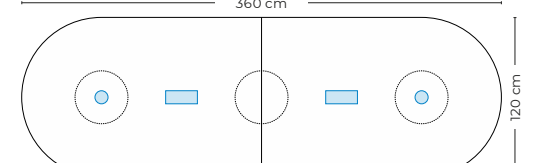

DR1G043612C

140 cm width

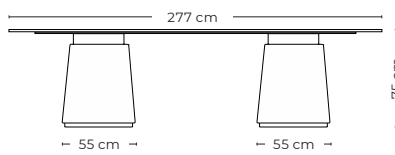

SC

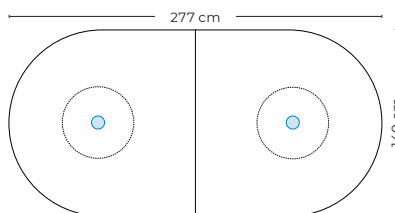

DR1G042714C

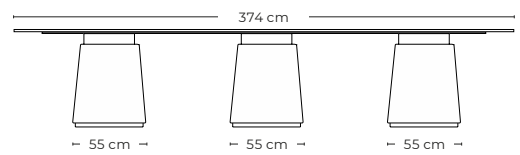

SC QC RC

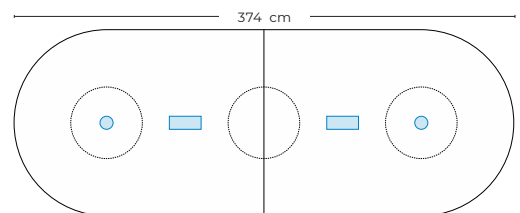

DR1G043714C

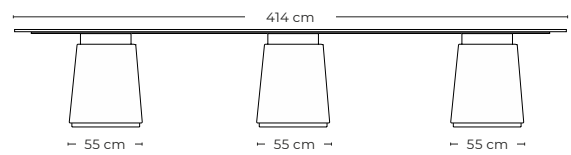

SC QC RC

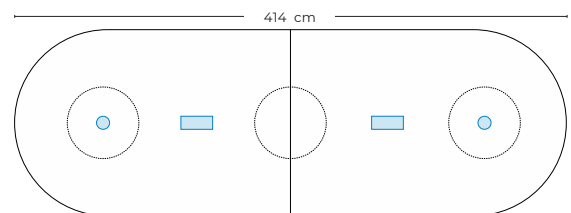

DR1G044114C

Coffee tables · Height 35 cm

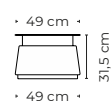

DR1S010049A

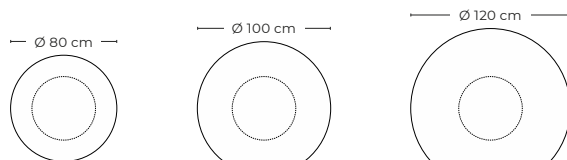

DR1T010080K DR1T010100K DR1T010120K

Contract tables · Height 105 cm

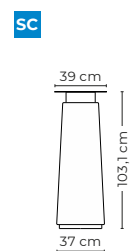

DR1S020036D

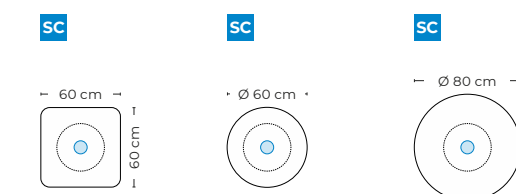

DR1T026060J DR1T030060J DR1T030080J

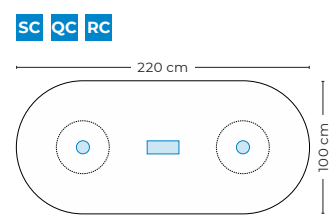
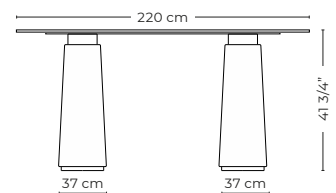

DR1G042210D

## Technical profile

Dorik · Contract tables height 74 cm · Column height 72,1 cm and diameter 40 cm



## Available desk-top dimensions

70 x 70 cm  
80 x 80 cmØ 80 cm  
Ø 100 cm

- 1 Column made of polyethylene by rotational moulding with an average thickness of 6 mm. Available in different finishes.
- 2 Black injected polypropylene (PP) levellers.
- 3 Inner counterweight of 60 kg. Three bags of soil to be ordered separately.
- 4 Structure realized in sheet steel of 3 mm of thickness, like support of the work surface. Black finish.



OUTDOOR

Option available for outdoor use, **provided the desk-top finishes is in compact laminate or Dekton®** and does not have electrical accessories.

Dorik · Meeting tables height 74 cm · Column height 70,5 cm and diameter 55 cm



## Available desk-top dimensions



Ø 120 cm

- 1 Column made of polyethylene by rotational moulding with an average thickness of 6 mm. Available in different finishes.
- 2 Black injected polypropylene (PP) levellers.
- 3 Inner counterweight of 80 kg. Four bags of soil to be ordered separately.
- 4 Structure realized in sheet steel of 3 mm of thickness, like support of the work surface. Black finish
- 5 Work top surface included in the reference, offered in different finishes.



OUTDOOR

Option available for outdoor use, **provided the desk-top finishes is in compact laminate or Dekton®** and does not have electrical accessories.

## Available desk-top dimensions

Ø 140 cm  
Ø 160 cm

- 1 Column made of polyethylene by rotational moulding with an average thickness of 6 mm. Available in different finishes.
- 2 Black injected polypropylene (PP) levellers.
- 3 Inner counterweight of 80 kg. Four bags of soil to be ordered separately.
- 4 Structure realized in melamine board of 16 mm of thickness, like support of the work surface. Black finish
- 5 Work top surface included in the reference, offered in different finishes.

Dorik · Meeting tables height 74 cm · Two columns

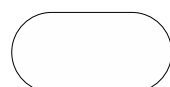

## Available desk-top dimensions

220 x 120 cm      277 x 140 cm  
240 x 120 cm

- 1 Column made of polyethylene by rotational moulding with an average thickness of 6 mm. Available in different finishes.
- 2 Black injected polypropylene (PP) levellers.
- 3 Inner counterweight of 60 kg per column, a total counterweight of 120 kg. Six bags of soil to be ordered separately.
- 4 Structure realized in melamine board of 16 mm of thickness, like support of the work surface. Black finish
- 5 Work top surface included in the reference, offered in different finishes.

## Technical profile

## Dorik · Meeting tables height 74 cm · Three columns



## Available desk-top dimensions

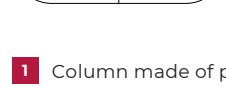

	320 x 120 cm	374 x 140 cm
	360 x 120 cm	414 x 140 cm

- 1** Column made of polyethylene by rotational moulding with an average thickness of 6 mm. Available in different finishes.
- 2** Black injected polypropylene (PP) levellers.
- 3** Inner counterweight of 60 kg per column, a total counterweight of 120 kg. Six bags of soil to be ordered separately.
- 4** Structure realized in melamine board of 16 mm of thickness, like support of the work surface. Black finish
- 5** Work top surface included in the reference, offered in different finishes.

## Dorik · Coffee table height 35 cm · Column height 331 mm and diameter 49 cm



## Available desk-top dimensions

	Ø 80 cm
	Ø 100 cm
	Ø 120 cm

- 1** Column made of polyethylene by rotational moulding with an average thickness of 6 mm. Available in different finishes.
- 2** Black injected polypropylene (PP) levellers.
- 3** Inner counterweight of 40 kg. Two bags of soil to be ordered separately.
- 4** Structure realized in sheet steel of 3 mm of thickness, like support of the work surface. Black finish



OUTDOOR

Option available for outdoor use, **provided the desk-top finishes is in compact laminate or Dekton®** and does not have electrical accessories.

## Dorik · Contract tables height 105 cm · Column height 103,1 cm and diameter 37 cm



## Available desk-top dimensions

	60 x 60 cm		Ø 60 cm
			Ø 80 cm

- 1** Column made of polyethylene by rotational moulding with an average thickness of 6 mm. Available in different finishes.
- 2** Black injected polypropylene (PP) levellers.
- 3** Inner counterweight of 60 kg. Three bags of soil to be ordered separately.
- 4** Structure realized in sheet steel of 3 mm of thickness, like support of the work surface. Black finish



OUTDOOR

Option available for outdoor use, **provided the desk-top finishes is in compact laminate or Dekton®** and does not have electrical accessories.

**Finishes available**

**Desk-top**

**MFC** · Thickness: 19 mm with straight edge

Chipboard with melamine surface in different finishes with a thickness of 19 mm.

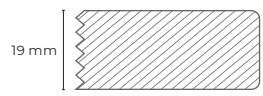
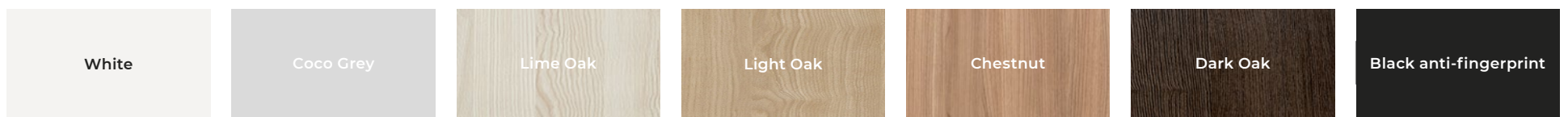

**Compact Laminate** · Thickness: 10 mm with bevelled edge

10 mm thick compact board made of wood fibres. With white or decorated high pressure laminate and bevelled edge.

**Black core**



**Coloured core**

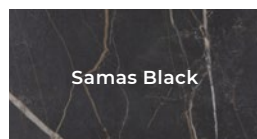
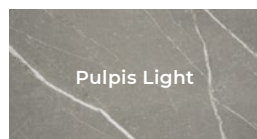
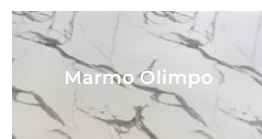

**Coloured core with textured surface**

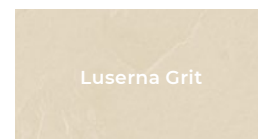

**MDF** · Thickness: 19 mm with bevelled edge

Medium density fibreboard laminated with natural wood in oak finish with a thickness of 19 mm and with a bevelled edge

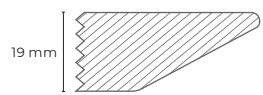
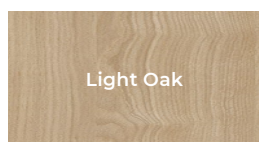

**Dekton®** · Thickness: 12 mm with bevelled edge

DEKTON® by Consentino, The Technical Ultracompact Stone, a sophisticated blend of raw materials used to manufacture state-of-the-art porcelain tiles. 12 mm thick and bevelled edge.

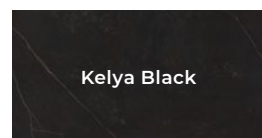
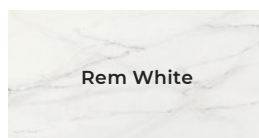

**STRUCTURE**

**Polythene**

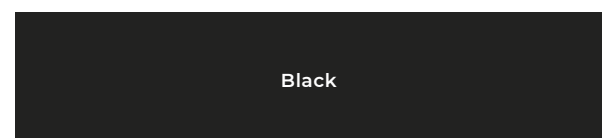
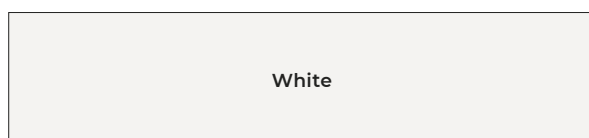

Available complements

Integrated electrical conduit



Electrified column with an inner tube made of steel with a diameter of 140 mm and bolted to the bottom of the column.

Electrification of meeting tables with 2 columns



Integrated electrical management consisting of an electrified column and an electrification trunking connecting the two columns. One of the two columns is electrified with an inner tube made of steel with a diameter of 40 mm and bolted to the bottom of the column. The electrification tray is made of folded sheet steel with a thickness of 3 mm.

Electrification of meeting tables with 2 columns



Integrated electrical management consisting of an electrified column and a two cables tray connecting the three columns. One of the three columns is electrified with an inner tube made of steel with a diameter of 40 mm and bolted to the bottom of the column. The electrification tray is made of folded sheet steel with a thickness of 3 mm.

Combination of integrated electrification tray finishes

<b>Structure</b>		<b>Structure</b>	
White	Mink	Black	
<b>Electrification tray</b>		<b>Electrification tray</b>	
White	Black		

## Packs, weights &amp; volumes

Columns		Packs	Weights	Volumes
<b>DRIS010040C</b> Contract tables Height 74 cm		2	8,2 kg	0,133 m <sup>3</sup>
<b>DRIS010055CL</b> Meeting tables Height 74 cm		2	11,97 kg	0,245 m <sup>3</sup>
<b>DRIS010055CN</b> Meeting tables Height 74 cm		2	13 kg	0,259 m <sup>3</sup>
<b>DRIS010055CP</b> Meeting tables Height 74 cm		2	15,49 kg	0,268 m <sup>3</sup>
<b>DRIS011969C</b> Meeting tables Height 74 cm		3	22,77 kg	0,274 m <sup>3</sup>
<b>DRIS010049A</b> Coffee tables Height 35 cm		2	8,37 kg	0,152 m <sup>3</sup>
<b>DRIS010036D</b> Contract tables Height 105 cm		2	9 kg	0,160 m <sup>3</sup>

Desk-top	Type of desk-top	Packs	Weights	Volumes
<b>DRIT026060J</b> 60 x 60 cm	MFC	1	4,31 kg	0,007 m <sup>3</sup>
	Compact Laminate		3,60 kg	0,004 m <sup>3</sup>
	Dekton®		10,80 kg	0,005 m <sup>3</sup>
<b>DRIT030060J</b> Ø 60 cm	MFC	1	3,38 kg	0,007 m <sup>3</sup>
	Compact Laminate		2,83 kg	0,004 m <sup>3</sup>
	Dekton®		8,48 kg	0,005 m <sup>3</sup>
<b>DRIT027070J</b> 70 x 70 cm	MFC	1	5,87 kg	0,010 m <sup>3</sup>
	Compact Laminate		4,90 kg	0,005 m <sup>3</sup>
	Dekton®		14,70 kg	0,006 m <sup>3</sup>
<b>DRIT028080J</b> 80 x 80 cm	MFC	1	7,66 kg	0,013 m <sup>3</sup>
	Compact Laminate		6,40 kg	0,007 m <sup>3</sup>
	Dekton®		19,20 kg	0,008 m <sup>3</sup>
<b>DRIT030080J</b> <b>DRIT010080K</b> Ø 80 cm	MFC	1	6,01 kg	0,013 m <sup>3</sup>
	Compact Laminate		5,02 kg	0,007 m <sup>3</sup>
	MDF		7,16 kg	0,013 m <sup>3</sup>
	Dekton®		15,0 kg	0,008 m <sup>3</sup>
<b>DRIT030100J</b> <b>DRIT010100K</b> Ø 100 cm	MFC	1	9,40 kg	0,015 m <sup>3</sup>
	Compact Laminate		7,85 kg	0,008 m <sup>3</sup>
	MDF		11,19 kg	0,015 m <sup>3</sup>
	Dekton®		23,55 kg	0,010 m <sup>3</sup>
<b>DRIT010120K</b> Ø 120 cm	MFC	1	13,53 kg	0,022 m <sup>3</sup>
	Compact Laminate		11,30 kg	0,012 m <sup>3</sup>
	MDF		16,11 kg	0,022 m <sup>3</sup>
	Dekton®		33,91 kg	0,014 m <sup>3</sup>
<b>DRIT030140L</b> Ø 140 cm	MFC	1	18,42 kg	0,030 m <sup>3</sup>
	Compact Laminate		15,39 kg	0,016 m <sup>3</sup>
	MDF		21,93 kg	0,030 m <sup>3</sup>
<b>DRIT030160L</b> Ø 160 cm	MFC	1	24,05 kg	0,039 m <sup>3</sup>
	Compact Laminate		20,10 kg	0,021 m <sup>3</sup>
	MDF		28,64 kg	0,039 m <sup>3</sup>
<b>DRIT042412L</b> 240 x 120 cm	MFC	1	30,77 kg	0,055 m <sup>3</sup>
	Compact Laminate		48,84 kg	0,029 m <sup>3</sup>
	MDF		36,63 kg	0,055 m <sup>3</sup>

### Ecodesign

Recycled materials	-
Production	100%
Transportation	100%
Use	Very easy
Disposal	-

**Recycled materials:** Maximum use of materials to eliminate waste and minimize residues. Use of recyclable materials and recycled materials in components that do not affect functionality and durability. **Production:** Maximum optimization of energy use. Minimum environmental impact. State-of-the-art technological systems. Zero wastewater discharge. VOC-free coatings. Processes free of heavy metals, phosphates, OC and COD. **Transport:** Dismountable systems. Volumes that facilitate space optimization. Maximum reduction of energy consumption for transport. **Use:** Quality and guarantee. Long useful life. Possibility of substitution and replacement of elements. **Disposal:** Waste reduction. Reuse system of supplier-manufacturer packaging. Easy separation of components. Solvent-free water-based printing inks on packaging.

### Regulations & EPD

Dorik has passed the tests carried out in our laboratory and the tests performed at the Instituto Tecnológico del Mueble (AIDIMME) corresponding to the standards:

Regulations	Description
UNE-EN 15372:2024	Furniture. Strength, durability and safety. Requirements for non-domestic tables.

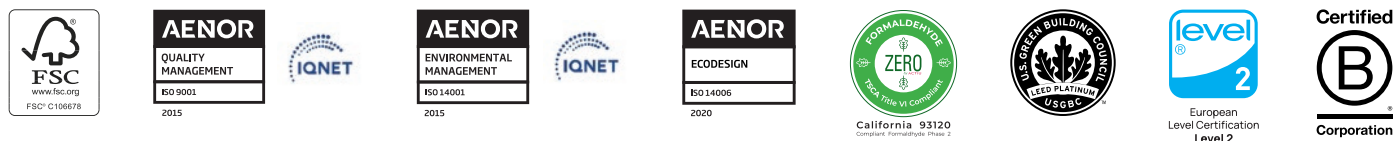

### Certificates



### Awards

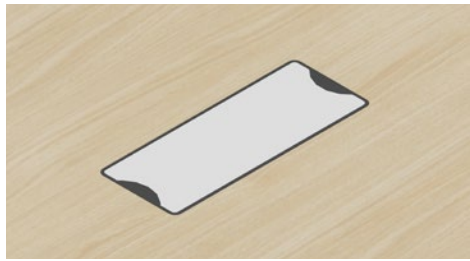
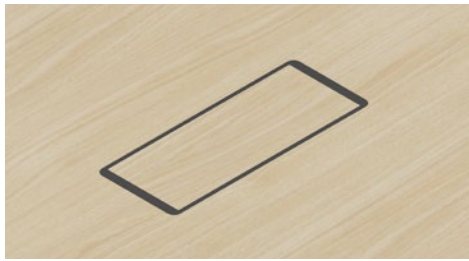

Access to wiring and connections

WIRING ACCESS <b>S</b>	WIRING ACCESS <b>Q</b>	WIRING ACCESS <b>R</b>	
			
	MAXIMUM OPENING 110°.	MAXIMUM OPENING 180°.	MAXIMUM OPENING 110°.
Surface-mounted wiring access, with easy surface access and reduced dimensions. The S-outlet access is the epitome of compact versatility, making it possible to combine 1 power socket and USB Type A and Type C connections in standard charging for mobile devices and tablets. Not compatible for outdoor use. Dimensions: Ø 70 mm	Black aluminum injected frame. Aluminum injected cover. Aluminum guides for adjustment according to the thickness of the surface between 13 and 30 mm. Dimensions: 305 x 121 mm.	MFC cover with the same finish as the surface. Black bristle brush. Black aluminum injected frame. Aluminum guides for adjustment according to the thickness of the surface between 13 and 30 mm. Complete 180° opening by means of hinges. Dimensions: 305 x 121 mm.	COMPACT LAMINATE cover with the same finish as the surface. Black bristle brush. Black aluminum injected frame. Aluminum guides for adjustment according to the thickness of the surface 10 mm. Dimensions: 305 x 121 mm.

- The models that incorporate these accesses in a standardized way show the corresponding icon or icons together with their reference.
- The price of the tables with WIRING access will be increased for each unit incorporated, according to the price indicated in the attached table.
- To request other tables with access to wiring that do not have standardized outlets (they will not contain any icon), please consult with the sales department.
- To request a table with access above the wiring, the following coding must be added at the end of the requested reference, according to its placement.

CENTERED ACCESS
<b>SC QC RC</b>

Combinations of finishes offered

SURFACE AND STRUCTURE FINISHES		COMBINATIONS OF FINISHES OFFERED		
Surface	Structure	Q WIRING ACCES	R WIRING ACCES	
MFC · WHITE	WHITE	WHITE	MFC · WHITE	
	MINK			
	BLACK			
MFC · COCO GREY	WHITE	WHITE	MFC · COCO GREY	
	MINK	BLACK		
	BLACK	BLACK		
MFC · LIME OAK	WHITE	WHITE	MFC · LIME OAK	
	MINK	BLACK		
	BLACK	BLACK		
MFC · LIGHT OAK	WHITE	WHITE	MFC · LIGHT OAK	
	MINK	BLACK		
	BLACK	BLACK		
MFC · CHESTNUT	WHITE	WHITE	MFC · CHESTNUT	
	MINK	BLACK		
	BLACK	BLACK		
MFC · DARK OAK	WHITE	BLACK	MFC · DARK OAK	
	MINK			
	BLACK			
MDF · BLACK ANTI-FINGERPRINT	WHITE	BLACK	MDF · NEGRO ANTI-FINGERPRINT	
	MINK			
	BLACK			
COMPACT LAMINATE · TRAFFIC WHITE	WHITE	WHITE	COMPACT LAMINATE · TRAFFIC WHITE	
	MINK			
	BLACK			
COMPACT LAMINATE · MARMO OLIMPO	WHITE	WHITE	COMPACT LAMINATE · MARMO OLIMPO	
	MINK			
	BLACK			
COMPACT LAMINATE · PULPIS LIGHT	WHITE	BLACK	COMPACT LAMINATE · PULPIS LIGHT	
	MINK			
	BLACK			
COMPACT LAMINATE · SAMAS BLACK	WHITE	BLACK	COMPACT LAMINATE · SAMAS BLACK	
	MINK			
	BLACK			
COMPACT LAMINATE · LUSERNA GRIT	WHITE	BLACK	COMPACT LAMINATE · LUSERNA GRIT	
	MINK			
	BLACK			

\* **Important note:** The combination of the accesses with wiring is carried out as follows (If in any of the cases it is desired that the electrification output be in a different finish than the one established, the client must expressly indicate it in the order).

Superior cable access location to cabling and connections

Meeting tables

Centered access

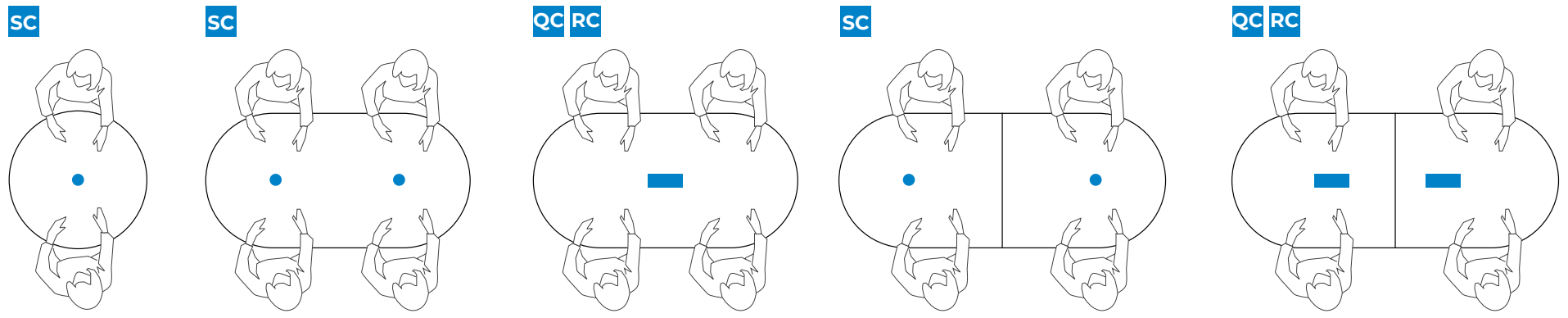



## ACTIU TECHNOLOGY PARK

### DESIGN & ARCHITECTURE

Space management and design  
Products. Own patents  
Communication

### SUSTAINABILITY

Sustainable production  
Product. Eco-design  
Services, efficient logistics system  
Actiu Technology Park, certified LEED®  
Platinum

### MANUFACTURER

We are manufacturers  
Domain raw materials and processes  
Technology and Innovation  
Standardized and specific solutions

### GLOBAL COVERAGE

Presence in more than 90 countries  
Global equipment solutions. Corporate, Health,  
Education, Contract, Transport.

### CERTIFICATES AND REFERENCES

ACTIU products fulfill all demands about management, quality and sustainability to provide extra value to the projects using recycled materials to get the recyclable final product.



Actiu, the first industrial company  
in the world to obtain the  
**WELL v2 and LEED Platinum Certification**



### ACTIU: 50 YEARS DESIGNING PUBLIC SPACES AND WORKSPACES.

Actiu is an industrial company working within the installation sector and specialising in the manufacture of furniture. Actiu's flexibility and productive capacity enable the company to carry out comprehensive equipment projects worldwide, providing solutions that favour the wellbeing of people.

### ACTIU, 50 AÑOS DISEÑANDO ESPACIOS PÚBLICOS Y DE TRABAJO.

Actiu es una empresa con una trayectoria industrial en el sector de la instalación, especializada en la creación de mobiliario, cuya flexibilidad y capacidad productiva permite desarrollar proyectos de equipamiento global a nivel internacional aportando soluciones que ofrezcan el bienestar de las personas.

### ACTIU, 50 ANS DE CONCEPTION D'ESPACES PUBLICS ET DE TRAVAIL.

Actiu est une entreprise dotée d'un parcours à caractère industriel dans le secteur de l'installation, qui se spécialise dans la création de mobilier, et dont la flexibilité et la capacité de production permettent de développer des projets d'équipement global à un niveau international, tout en apportant des solutions qui puissent offrir du bien-être aux personnes.

### ACTIU, 50 JAHRE DESIGN UND PRODUKTION VON MÖBELN FÜR ÖFFENTLICHE EINRICHTUNGEN UND ARBEITSRÄUME.

Unsere ständige Forschung, Weiterentwicklung, Flexibilität und Erfahrung ermöglichen es uns, Projekte im privaten und öffentlichen Bereich der verschiedensten Sektoren auf nationaler und internationaler Ebene durchzuführen. Stillstand ist uns fremd. Uns treibt das Bedürfnis an, näher an den Menschen zu sein und Lösungsmöglichkeiten zu entwickeln, die den Endnutzern Wohlgefühl bieten.

ACTIU reserves the right to carry out technical, dimensional and finishing modifications that it considers appropriate with respect to the information detailed in this document, so please check before confirming your orders.

ACTIU se reserva el derecho de llevar a cabo las modificaciones técnicas, dimensionales y de acabados que estime conveniente respecto a la información detallada en este documento, por el que se ruega verificación antes de confirmar sus pedidos.

We dream to go beyond our own immediate reality. We design to mature our desires. We walk because only our initiative changes the world and breaks new ground. We move ourselves by being ourselves without the fear of underperforming against our own expectations and goals.

### D. Vicente Berbegal Pérez

President and Founder of the Actiu Group.



ACTIU, National Design Award 2017  
ACTIU, Premio Nacional de Diseño 2017

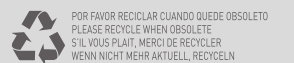

# CREDITS

COORDINATION:  
ACTIU

DESIGN AND LAYOUT:  
ODOSDESIGN

ART DIRECTION:  
ODOSDESIGN

IMAGES:  
JOSELE CASTELLÓ  
ALFONSO CALZA  
RAFA GALÁN  
ACTIU  
ODOSDESIGN

THANKS TO:  
VIBIA

LOCATION:  
RODES. ARCHITECTURE BY RAMÓN ESTEVE ESTUDIO  
THANKS TO: AJUNTAMENT D'ALCOI





ACTIU

[actiu.com](http://actiu.com)