

# FOLLOW MEETING LARGE MONOCHROMATIC 298MLCAR

# mara

## DESCRIPTION / DESCRIZIONE

**en** Follow Meeting Large is the sit-stand table for conviviality. "No-gravity" is the name of Mara's innovative patented system to adjust the height of a top as big as 3000x1400 mm, with a simple touch. An intuitive, quick and silent regulation. 100% recyclable (and sustainable) Follow Meeting Large fulfills the requirements of ergonomics and comfort for working as well as domestic environments. Sturdy and steady the structure of the table comprises a twin base in powder-coated steel and an integrated cable tray. An array of colours and finishes let this table be customized in multiple combinations.

**it** Follow Meeting Large è il grande tavolo conviviale, regolabile in altezza. L'innovativo sistema "no-gravity" brevettato Mara consente di regolare, con il semplice tocco di una maniglia, l'altezza di un piano grande fino a 3000x1400 mm in modo intuitivo, veloce e silenzioso. 100% riciclabile (e sostenibile), Follow Meeting Large è un tavolo sit-stand che risponde ai bisogni di ergonomia e comfort non solo negli uffici ma anche in contesti residenziali. Struttura stabile e robusta composta da una doppia base in acciaio verniciato e da una vasca porta cavi integrata. Un'ampia scelta di colori e finiture permette la personalizzazione del tavolo in molteplici combinazioni.

FOLLOW MEETING LARGE  
**monochromatic sit-stand table**  
tavolo regolabile in altezza monocromatico

**298MLCAR**

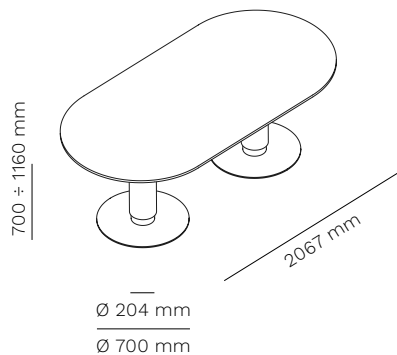

top  
2600 - 3000 x 1200 - 1400 mm

INNOVATION AWARD  
ARCHITECTURE+  
OFFICE  
2022 SPECIAL MENTION



**Seal of Excellence from the European Union's 2020 Research and Innovation Programme.**

Sigillo d'Eccellenza dal Programma di Ricerca e Innovazione dell'Unione Europea Horizon 2020.



**patented system**  
sistema brevettato



**no electricity**  
no elettricità



**version with FSC® certified top**  
versione con piano certificato FSC®



**fast**  
veloce



**silent**  
silenzioso



**adjustable height**  
altezza regolabile



<b>2 BASES</b> 2 BASI	<b>20 Kg /</b> cad	<b>1 pc</b> 0,015 mc	<b>6 pcs /</b> 160 x 100 cm pallet
<b>1 BEAM</b> 1 TRAVERSA	<b>4,5 kg</b>	<b>1 pc</b> 0,057 mc	<b>30 pcs /</b> 160 x 110 cm pallet
<b>2 UNDER-TOP CROSSES</b> 2 CROCIERE	<b>7,5 kg /</b> cad	<b>1 pc</b> 0,073 mc	<b>27 pcs /</b> EU pallet
<b>2 COLUMNS</b> 2 COLONNE	<b>23,7 kg</b> / cad	<b>1 pc</b> 0,081 mc	<b>12 pcs /</b> EU pallet

# FOLLOW MEETING LARGE MONOCHROMATIC 298MLCAR

# mara

## INCLUDED ACCESSORIES / ACCESSORI INCLUSI

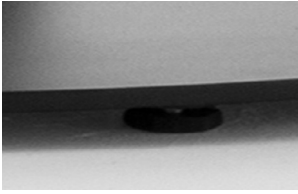

**foot levelers**  
piedini livellatori

## ACCESSORIES / ACCESSORI

### 299FZ



**counter balance kit**  
(2 zavorre 1,2 kg/cad.)  
counter balance kit  
(2 x 1,2 kg ballasts)

### 511PLUS



**top access with flip cover**  
passacavi con sportello

### 511EPLUS



**top access with multifunctional sockets**  
passacavi con prese multifunzione

### PASD60



**multifunctional sockets**  
Ø 60 mm  
prese multifunzione  
Ø 60 mm

### PASD80



**multifunctional sockets with wireless charging**  
Ø 80 mm  
prese multifunzione con ricarica wireless Ø 80 mm

### 299ME



**kit for electrification**  
kit per elettrificazione

### 300



**cpu holder**  
portaserver

### 500DROLL



**mobile storage system, on castors**  
cassettiera mobile su ruote

### VERTEBRE



**Flexible cable management**  
Vertebra flessibile in rete

# FOLLOW MEETING LARGE MONOCHROMATIC 298MLCAR

# mara

## FRAME / STRUTTURA

**powder coated steel**  
acciaio verniciato



**296**  
**textured**  
raggrinzato  
RAL 9010



**819**  
**textured**  
raggrinzato  
RAL 8019



**420**  
**textured**  
raggrinzato



**333**  
**textured**  
raggrinzato  
RAL 3003



**111**  
**textured**  
raggrinzato  
RAL 5011



**203**  
**textured**  
raggrinzato  
RAL 6003



**700**  
**textured**  
raggrinzato  
RAL 7000



**444**  
**textured**  
raggrinzato  
RAL 8004



**301**  
**textured**  
raggrinzato  
RAL 7044



**131**  
**textured**  
raggrinzato  
RAL 9006



**148**  
**textured**  
raggrinzato  
RAL 7016



**120**  
**textured**  
raggrinzato  
RAL 9005

## TOP / PIANO

**standard FENIX tops**  
piani standard in FENIX



**0754**  
Blu  
Fes



**0791**  
Giallo  
Evora



**0751**  
Rosso  
Jaipur



**0750**  
Verde  
Comodoro



**0032**  
Bianco  
Kos



**0720**  
Nero  
Ingo

**STANDARDS AND CERTIFICATES / NORME E CERTIFICATI**  
Resistance to scratching EN 438-2:2019 - CL.25 Class  $\geq 4$  •  
Resistance to staining EN 438-2:2019 - CL.26 Group 1 e 2: Class 5 Group 3: Class  $\geq 4$  • Resistance to dry heat (160°C/20') - EN 438-2:2019 - CL.16 Class 5 • Lightfastness (xenon arc) EN 438-2:2019 - CL.27 Grayscale classification  $\geq 4$  • Resistance to steam

EN 438-2:2019 - CL.14 Class 5 • Specular surface reflection ISO 2813 8 ÷ 16 a 85° Unità Gloss • Resistance to surface wear EN 438-2:2019 - CL.10 Rotation value IP  $\geq 200$  • Resistance to damp heat (100°C/20') - EN 438-2:2019 - CL.18 Class 5

**TOP / PIANO**

**standard colour and material effect laminate tops**

piani standard in laminato colore ed effetto materico



**white**  
bianco



**magnolia**



**light grey**  
grigio  
chiaro



**anthracite**  
antracite



**black**  
nero



**white marble**  
marmo  
bianco



**graphite marble**  
marmo  
grafite



**black marble**  
marmo  
nero



**cement**  
cemento



**iron**  
ferro



**whitened oak**  
rovere  
sbiancato



**natural oak**  
rovere  
naturale



**grey oak warm**  
rovere  
grigio warm



**walnut**  
noce



**blue**  
blu



**light blue**  
azzurro



**powder**  
cipria



**terracotta**  
terracotta



**red**  
rosso

**STANDARDS AND CERTIFICATES / NORME E CERTIFICATI**

Dimensional tolerance related to the thickness  $\pm 0,3$  mm • Dimensional tolerance related to the sizes  $\pm 5,0$  mm • Resistance to scratching EN 438-2:2016 Class 3 • Resistance to staining EN 438-2:2016 Group 1 e 2: Class  $\geq 4$  Group 3: Class  $\geq 4$  • Resistance to dry heat (160°C/20') - EN 438-2 Class 4 • Lightfastness (xenon arc) EN 438-2 Grayscale classification  $\geq 4$

• Resistance to steam EN 438-2 Class 4 • Resistance to surface wear EN 438-2 Rotation value IP  $\geq 150$  • Resistance to damp heat (100°C/20') - EN 438-2 Class 4

**standard colour, material effect and soft touch melamine tops**

piani standard in nobilitato colore, effetto materico e soft touch



**white**  
bianco



**magnolia**



**light grey**  
grigio  
chiaro



**anthracite**  
antracite



**black**  
nero



**whitened oak \***  
rovere  
sbiancato



**natural oak \***  
rovere  
naturale



**grey oak warm \***  
rovere  
grigio warm



**walnut\***  
noce



**T1 white**  
bianco



**T2 black**  
nero



**T6 brown**  
marrone



**T8 blue**  
blu



**cement\***  
cemento



**iron\***  
ferro

**\* top finishes available only up to 2800 mm width**  
\* finiture disponibili solo fino a 2800 mm di larghezza

**STANDARDS AND CERTIFICATES / NORME E CERTIFICATI**

Dimensional tolerance related to the sizes  $\pm 5,0$  mm • Resistance to scratching 1,5 N • Resistance to cigarette burning 3 grade - moderate change in gloss level and/or moderate brown spots • Resistance to surface wear Rotation value IP  $< 50$  Rotation value WR  $< 150$  • Risk of breakage  $\geq 3$  group • Dimensional tolerance related to the thickness  $15 \leq X \leq 20$  mm :  $\pm 0,3$  mm X  $< 20$  mm :  $\pm 0,5$  mm • Resistance to staining  $\geq 3$  group

• Resistance to steam 4 grade - moderate change in gloss level and/or color • Surface imperfections Prolate imperfections:  $< 20$  mm/m Punctiform imperfections:  $< 2$  mm<sup>2</sup>/m<sup>2</sup> • Lightfastness (xenon arc)  $> 6$  group

**CLEANING AND MAINTENANCE / PULIZIA E MANUTENZIONE**

**STEEL / ACCIAIO**

**en** Our types of metals include: chromed metals and painted metals. Do not use acid or alkaline based cleaning products. Do not use detergents, steel wool, dishwashing detergents or the like. Sharp or pointed objects may damage the surface. Any hot or wet object may cause surface damage. Clean the surface regularly with a soft cloth to remove dust. To remove light dirt, use a soft cloth and a neutral household cleaner.

**it** Le nostre tipologie di metallo comprendono: metalli cromati e metalli verniciati. Non utilizzare prodotti per la pulizia a base acida o alcalina. Non utilizzare detergenti, lana di acciaio, detersivi per stoviglie o simili. Oggetti appuntiti o taglienti possono danneggiare la superficie. Qualsiasi oggetto caldo o bagnato potrebbe provocare danni alla superficie. Pulire la superficie regolarmente con un panno soffice per rimuovere la polvere. Per rimuovere lo sporco leggero utilizzare un panno soffice e un prodotto per le pulizie di casa neutro.

**CHROMED STEEL AND ALUMINIUM POLISHED / ACCIAIO CROMATO E ALLUMINIO LUCIDO**

**en** Do not use acid or alkaline based cleaning products. Do not use detergents, steel wool, dishwashing detergents or the like. Sharp or pointed objects may damage the surface. Any hot or wet object may cause surface damage. Clean the surface regularly with a soft cloth to remove dust. To remove light dirt, use a soft cloth and a neutral household cleaner

**it** Non utilizzare prodotti per la pulizia a base acida o alcalina. Non utilizzare detergenti, lana di acciaio, detersivi per stoviglie o simili. Oggetti appuntiti o taglienti possono danneggiare la superficie. Qualsiasi oggetto caldo o bagnato potrebbe provocare danni alla superficie. Pulire la superficie regolarmente con un panno soffice per rimuovere la polvere. Per rimuovere lo sporco leggero utilizzare un panno soffice e un prodotto per le pulizie di casa neutro.

**LAMINATE AND MELAMINE / LAMINATI E NOBILITATI**

**en** Laminates and melamine products guarantee high performance in terms of resistance to scratches, shocks and abrasions. Keep furniture away from direct sunlight; furniture in direct sunlight may tend to discolour over time. Do not use acid or alkaline based cleaning products. Sharp or pointed objects can damage the surface. Laminate and melamine furniture can be cleaned using a mixture of liquid soap and hot water. Rinse with cold water and dry with a paper towel or damp cloth.

**it** Laminati e nobilitati garantiscono alte prestazioni di resistenza ai graffi, agli urti e alle abrasioni. Mantenere i mobili lontani dalla luce diretta del sole; i mobili che si trovano alla luce diretta del sole potrebbero tendere a scolorire nel tempo. Non utilizzare prodotti per la pulizia a base acida o alcalina. Oggetti appuntiti o taglienti possono danneggiare la superficie. E' possibile effettuare la pulizia dei mobili in laminato e nobilitato usando una miscela di sapone liquido e acqua calda. Sciacquare con acqua fredda e asciugare con un tovagliolo di carta o un panno umido.

**STANDARD FENIX TOPS / PIANI STANDARD IN FENIX**

**en** Cleaning FENIX means cleaning its structure. You can do this with warm water. As FENIX is a strong material, you can also use any household cleaner – even solvents like acetone \* if needed. However, to avoid damaging the structure, don't scrub it with abrasive cream, a scouring pad or a hard brush; in the long-term, this might lead to a glossy spot on your matt surface. Instead, you can use a melamine sponge – also known as a magic sponge. As a final step, to avoid anything staying behind in the structure – whether that's dirt or residue from your cleaner – always rinse afterward with warm water and wipe dry with a clean cloth.

\* always follow safety instructions

**it** Pulire FENIX significa pulirne la struttura. Si può farlo, usando acqua tiepida. Poiché FENIX è un materiale resistente, si può utilizzare qualsiasi detergente per la casa, se necessario anche un solvente come l'acetone \*. Tuttavia, per evitare di danneggiare la struttura, è consigliabile evitare di strofinarla usando una crema abrasiva, una spugna abrasiva o una spazzola con setole dure; nel tempo, ciò potrebbe portare alla formazione di un'area lucida sulla superficie opaca. Si può piuttosto utilizzare una spugna in melamina, nota anche come spugna magica. Come ultimo passaggio, per evitare la formazione di depositi nella struttura, che si tratti di sporco o residui del detergente, risciacquare sempre con acqua tiepida e asciugare con un panno pulito.

\* seguire sempre le istruzioni di sicurezza.

**TECHNICAL SPECIFICATION**  
298MLCAR MONOCHROMATIC



> Follow Meeting Large Monochromatic has a height range of 460 mm.

> Follow Meeting Large Monochromatic can be used with tops from 2600 mm to 3000 mm in length.

> The table frame is designed for optimal operation in a range of weights (top weight + accessories weight) between 45 and 53 kg.

> Depending on the intended use of the table, carefully evaluate the weight of the table top to be assembled.

> If a lighter table top is to be installed or if the table is to work without additional weight, the “counter-balance kit” is able to reduce 14,4 kg the upwards thrust allowing a correct functioning of the movement.

<b>Meeting Large Monochromatic</b>	min	max
<b>height range (mm)</b>	460	
<b>frame height (mm)</b>	700	1160
<b>top (mm)</b>	2600	3000
<b>table top weight + accessories recommended weight (kg)</b>	45	53
<b>counter-balance kit * (kg)</b>	1,2	14,4

\* optional

<b>TOP WEIGHTS</b>					<b>TOP + CLIENT LOADING RECOMMENDED WEIGHT (kg)</b>	
	Depth	Width			MIN	MAX
SINGLE TOP		2600 mm	2800 mm	3000 mm		
MELAMINE TOP 18/19 mm	1200 mm R600	36 kg	39 kg	44 kg	45	53
	1400 mm R700	41 kg	45 kg	48 kg		
MELAMINE TOP 25 mm	1200 mm R600	45 kg	49 kg	53 kg		
	1400 mm R700	52 kg	-	-		
LAMINATE AND FENIX TOP 20 mm	1200 mm R600	43 kg	47 kg	51 kg		
	1400 mm R700	50 kg	-	-		

**PLEASE NOTE: OBSERVE THE WEIGHTS INDICATED**

> A load, on the frame, exceeding the maximum weight indicated (top weight + accessories weight), causes a rapid lowering of the table top when unlocked.

> A load, on the frame, below the minimum weight indicated (top weight + accessories weight), causes an excessive upward thrust of the table when unlocked.

## INSTRUCTIONS FOR CORRECT USE

### FIRST USE:

A. Remove the safety-spacer from the adjustment handle (9a).

### ONLY IF NECESSARY:

A. Unscrew the nut (11b) and adjust the handle cable (11c): a clockwise rotation will loosen it, while a counter clockwise rotation will tighten it out. The adjustment is correct when the handle is neither loose nor hard.

B. Secure the nut (11b) after adjusting the cable tension of the handle (11c).

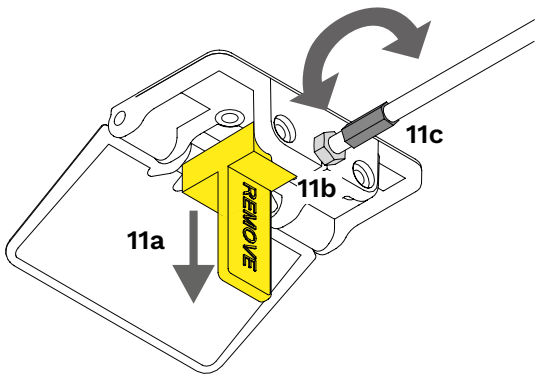

### DAILY USE:

1. Place one hand on the adjustment handle and the other hand on the same side of the table top, and operate the movement (fig. 1).
2. Using both hands, lift or lower the top to the desired height.
3. The table is easily adjustable.  
In case of difficult use, adjust the handles cable (see “only if necessary”).
4. Once the desired height has been reached, stop the movement and release the handle.  
The table will automatically lock in the desired position.

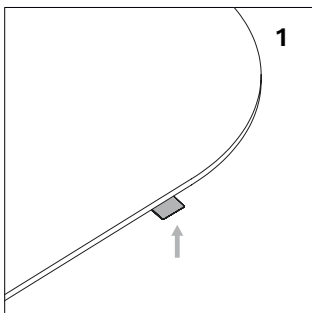

### ATTENTION

Any part of all components already assembled and supplied by the company cannot be disassembled unless this is done by Mara personnel. The assembly and disassembly of this table must be carried out by skilled operator following the instructions carefully.

**SPECIFICHE TECNICHE**  
298MLCAR MONOCROMATICO

**mara**

> Follow Meeting Large Monocromatico ha un'escursione in altezza di 460 mm.

> Follow Meeting Large Monocromatico può montare piani da 2600 mm a 3000 mm di lunghezza.

> Il telaio del tavolo è progettato per un funzionamento ottimale in un intervallo di pesi (peso piano + pesi accessori) compresi tra i 45 e i 53 kg.

> In base all'utilizzo previsto del tavolo, valutare attentamente il peso del piano da montare.

> Se è previsto il montaggio di un piano più leggero o non è previsto di caricare il piano di lavoro, l'accessorio "counter-balance kit" è in grado di ridurre fino a 14,4 kg la spinta verso l'alto permettendo il corretto funzionamento del movimento.

Meeting Large Monocromatico	min	max
escursione altezza (mm)	460	
altezza telaio (mm)	700	1160
piano (mm)	2600	3000
peso piano + peso accessori (kg) consigliato	45	53
counter-balance kit * (kg)	1,2	14,4

\* opzionale

PESI PIANI					PIANO + CARICO CLIENTE PESO CONSIGLIATO (kg)	
	Profondità	Lunghezza			MIN	MAX
PIANO SINGOLO		2600 mm	2800 mm	3000 mm		
PIANO IN NOBILITATO SP 18/19 mm	1200 mm R600	36 kg	39 kg	44 kg	45	53
	1400 mm R700	41 kg	45 kg	48 kg		
PIANO IN NOBILITATO SP 25 mm	1200 mm R600	45 kg	49 kg	53 kg		
	1400 mm R700	52 kg	-	-		
PIANO IN LAMINATO E FENIX SP 20 mm	1200 mm R600	43 kg	47 kg	51 kg		
	1400 mm R700	50 kg	-	-		

**ATTENZIONE: ATTENERSI AI PESI INDICATI**

> Un carico sopra il telaio superiore al peso massimo indicato (peso piano + peso accessori) causa un veloce abbassamento del piano al momento dello sblocco.

> Un carico sopra il telaio inferiore al peso minimo indicato (peso piano + peso accessori) causa un veloce innalzamento del piano al momento dello sblocco.

## ISTRUZIONI D'USO

### AL PRIMO UTILIZZO:

A. Rimuovere il distanziale di sicurezza inserito nella maniglia di regolazione (11a).

### SOLO SE NECESSARIO:

A. Svitare il dado (11b) e regolare il cavo della maniglia (11c): una rotazione oraria lo allenterà mentre una rotazione antioraria lo tenderà. La regolazione è corretta quando la maniglia non risulta nè libera ne troppo dura.

B. Fissare il dado (11b) una volta regolata la tensione del cavo (11c).

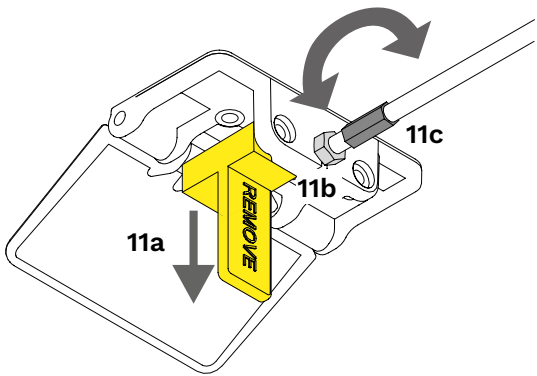

### USO QUOTIDIANO:

1. Posizionare la mano d'utilizzo sulla maniglia di regolazione e l'altra mano sullo stesso lato del piano e azionare il movimento (fig. 1).
2. Utilizzando entrambe le mani, sollevare o abbassare il piano all'altezza desiderata.
3. Il tavolo si regola facilmente.

In caso di difficoltà nell'utilizzo, migliorare la regolazione del cavo della maniglia (vedi "solo se necessario").

4. Raggiunta l'altezza desiderata fermare il movimento e rilasciare la maniglia di regolazione. Il tavolo si bloccherà automaticamente nella posizione desiderata.

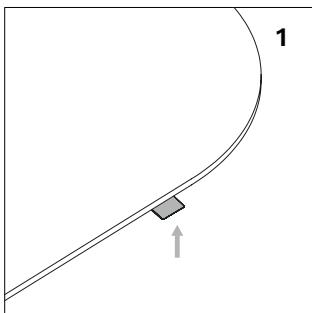

### ATTENZIONE

Ogni componente fornito già montato dall'azienda non può essere smontato in nessuna sua parte se non da personale Mara. Montaggio e smontaggio di questo tavolo deve essere effettuato da personale esperto seguendo attentamente le istruzioni.

## TOP ACCESS

PASSACAVI

511PLUS

# mara

### DESCRIPTION / DESCRIZIONE

**en Aluminium top access with flap. Black brush.**

**it Passacavi in alluminio con spazzola nera.**



1

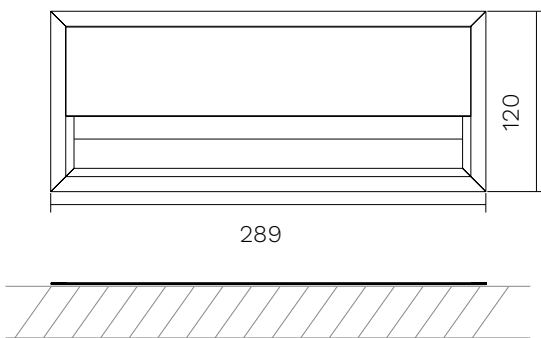

**All measurements are indicated in mm**  
Tutte le misure sono indicate in mm

### Surface cut-out area

Area di taglio della superficie

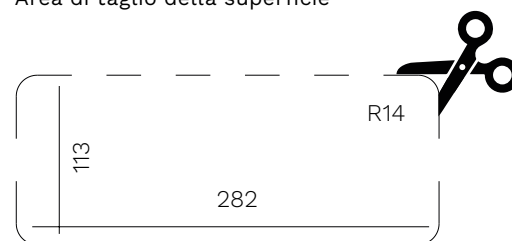

### COLOURS AVAILABLE / COLORI DISPONIBILI



**aluminium**  
alluminio



**black**  
nero



**TOP ACCESS WITH INTEGRATED POWER UNIT**  
**PASSACAVI CON MULTIPRESA INTEGRATA**



511EPLUS

**DESCRIPTION / DESCRIZIONE**

**en** Top access with integrated power unit for table tops max 30 mm thick, available in aluminium or black colour, 289x120 mm with 2 mt. power cable + 2 DE sockets + 2 USB 5V/2, 4A + 2 RJ45 sockets.

**it** Passacavo con multipresa integrata per piani tavoli spessore max 30 mm, disponibile nei colori alluminio o nero, 289x120 mm con 2 mt. di cavo di alimentazione + 2 presa DE + 2 prese USB 5V/2, 4A + 2 prese RJ45.



RJ45



DE



USB



1

**Optional  
 (on demand)\*:**  
 Opzionali  
 (su richiesta)\*:



HDMI



IT



FRA

\* dedicated quotation / quotazione dedicata

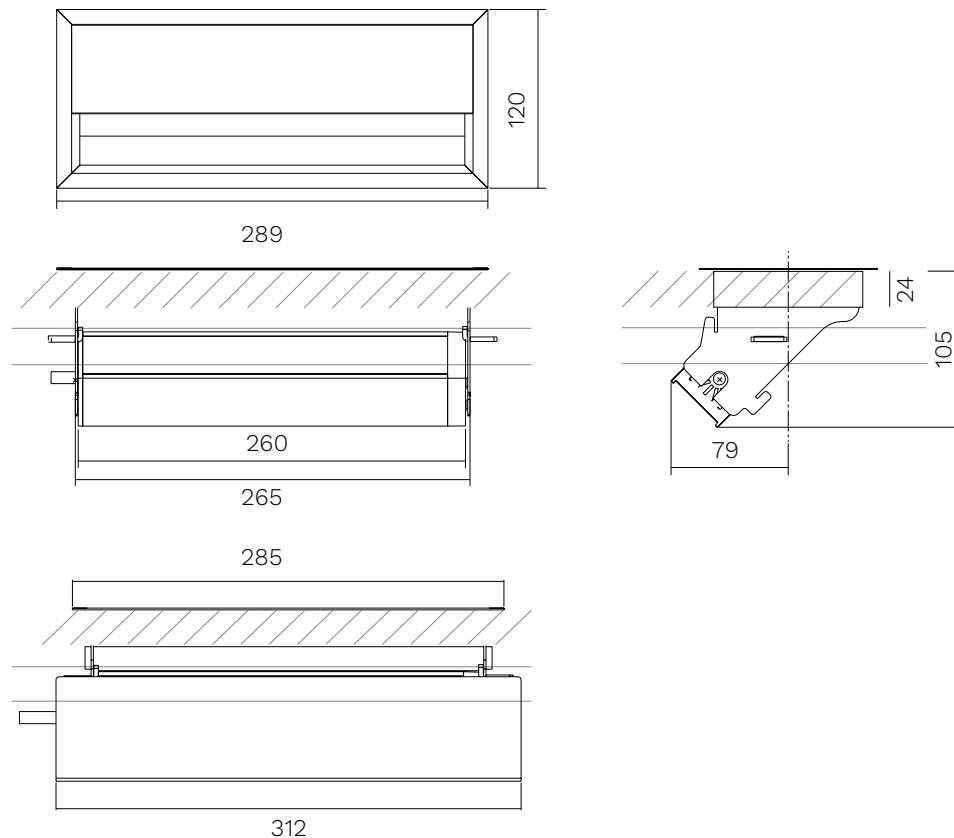

**Surface cut-out area**

Area di taglio della superficie



All measurements are indicated in mm  
 Tutte le misure sono indicate in mm

**COLOURS AVAILABLE / COLORI DISPONIBILI**

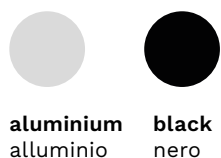

# TOP ACCESS WITH INTEGRATED MULTIFUNCTIONAL SOCKET

PASSACAVI CON MULTIPRESA INTEGRATA

# mara

PASD60

## DESCRIPTION / DESCRIZIONE

**en** Top access round with integrated multifunctional socket for table tops, available in white or black colours, diameter 60 mm with 1,5 mt. power cable + 1 DE + 1 USB 5V/2, 4A socket.

**it** Presa multifunzione rotonda per piani tavoli, disponibile nei colori bianco o nero, diametro 60 mm con 1,5 mt. di cavo di alimentazione + 1 presa DE + 1 presa USB 5V/2, 4A.



**Optional (on demand)\*:**  
Opzionali (su richiesta)\*:

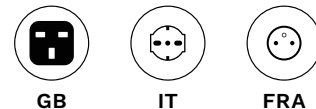

\* dedicated quotation / quotazione dedicata

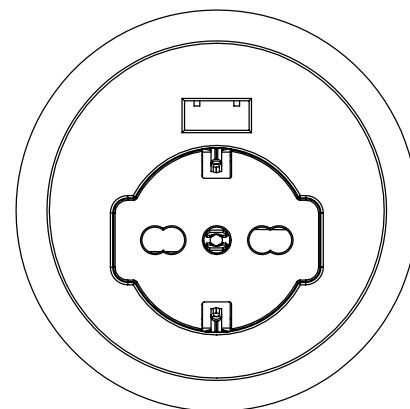
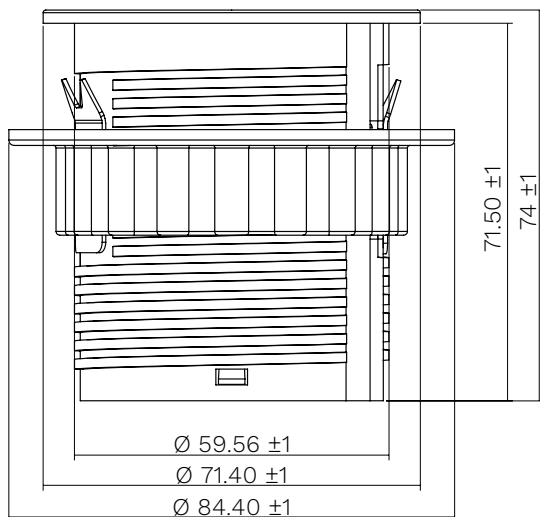

**Surface cut-out area**

Area di taglio della superficie

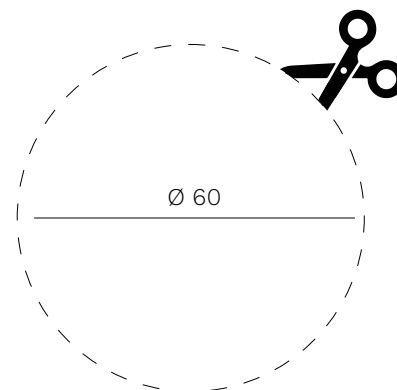

All measurements are indicated in mm  
Tutte le misure sono indicate in mm

## COLOURS AVAILABLE / COLORI DISPONIBILI



**white**  
bianco



**black**  
nero



# CABLE MANAGEMENT WITH INTEGRATED MULTISOCKET PASSACAVO CON MULTIPRESA INTEGRATA

# mara

PASD80

## DESCRIPTION / DESCRIZIONE

**en** Top access round with integrated multifunctional socket for table tops, available in white or black colours, diameter 80 mm with 2 mt. power cable + 1 DE + 2 USB 5V/2, 4A socket + 1 RJ45 (interchangeable). The inside of the cover is equipped with a wireless charger (usable only when open).

**it** Presa multifunzione rotonda per piani tavoli, disponibile nei colori bianco o nero, diametro 80 mm con 2 mt. di cavo di alimentazione + 1 presa DE + 2 prese USB 5V/2, 4A + 1 presa RJ45 (intercambiabile). L'interno del coperchio è provvisto di caricatore wireless (utilizzabile solo quando aperto).



wireless recharge

RJ45

DE

USB

1

**Optional (on demand)\*:**  
Opzionali (su richiesta)\*:



HDMI



EXIT



GB



IT



FRA

\* dedicated quotation and minimum order  
\* quotazione dedicata e minimo d'ordine

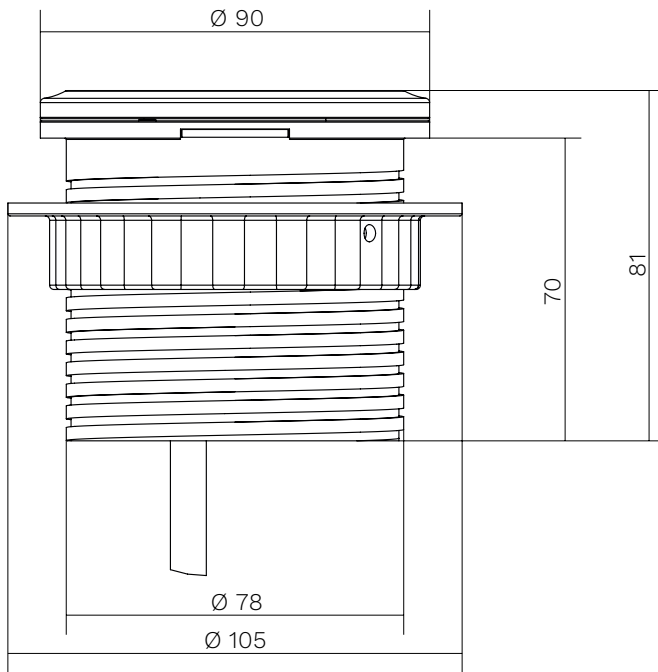

All measurements are indicated in mm  
Tutte le misure sono indicate in mm

## COLOURS AVAILABLE / COLORI DISPONIBILI



white  
bianco



black  
nero

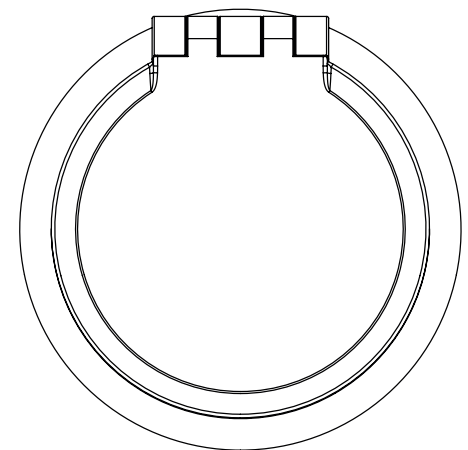

**Surface cut-out area**  
Area di taglio della superficie

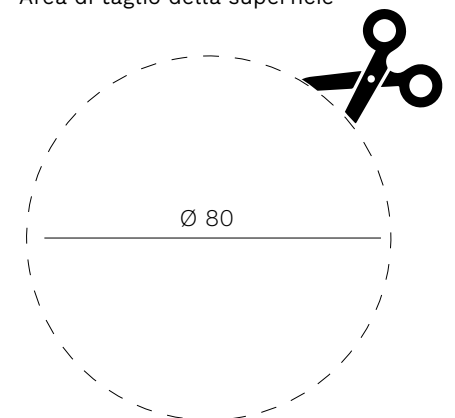

## FLEXIBLE CABLE MANAGEMENT

VERTEBRA FLESSIBILE IN RETE

VERTEBRE

# mara

### DESCRIPTION / DESCRIZIONE

**en** Flexible cable duct made of multifilament polyester, double slider zip, max. height 1300 mm, suitable for height-adjustable tables, complete with tabletop mounting plate and base with weight for greater stability

**it** Canalina flessibile realizzata in poliestere multifilamento, cerniera con doppio cursore, altezza max. 1300 mm, adatta a tavoli regolabili in altezza, completa di piastra di fissaggio al piano e base con peso per maggiore stabilità

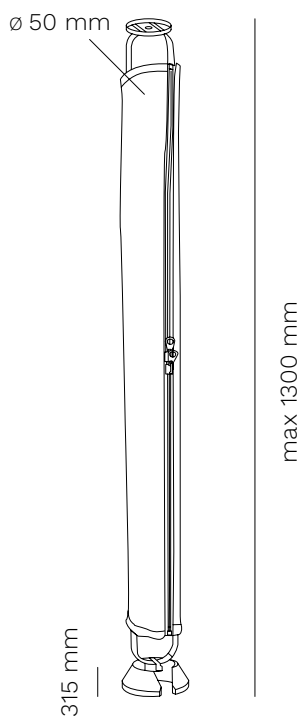

- Suitable for height-adjustable tables
- For table tops with a maximum height of 1300 mm
- Hinge with two sliders for opening from both the top and bottom
- Easy to attach to the table top with a single screw (included)
- Versatile thanks to the flexibility of the fabric

- Adatta a tavoli regolabili in altezza
- Per piani tavolo con altezza max. 1300 mm
- Cerniera con due cursori per apertura sia dall'alto che dal basso
- Fissaggio facilitato al piano tramite una sola vite (inclusa)
- Versatile grazie alla flessibilità del tessuto

### Flexible multi-filament polyester fabric

Tessuto flessibile in poliestere multifilamento



**Black**  
nero



**aluminium**  
alluminio



**white**  
bianco

**en** As it is always seeking to improve its products, the company reserves the right to modify or upgrade the products without prior notice, at any time. Colors should be considered purely indicative. Mara's Collections are worldwide protected by the industrial property right and patents.

**it** Mara, sempre alla ricerca del miglioramento dei propri prodotti, si riserva la facoltà di apportare modifiche costruttive e funzionali in qualsiasi momento senza alcun preavviso. I colori dei materiali sono da ritenersi puramente indicativi. Tutte le collezioni Mara sono protette nel mondo dal diritto di proprietà industriale e da brevetti registrati.

**FOLLOW MEETING MONOCHROMATIC**  
299MCAR



**DESCRIPTION / DESCRIZIONE**

**en** Follow is a height-adjustable table that effortlessly and noiselessly adjusts to the user's posture and need. The meeting version with powder coated steel frame and round top available up to 1600 mm in diameter, is ideal for meetings in office spaces but can also be used in meeting and convivial areas. Height-adjustable metal handle.  
Follow Meeting can be placed and moved anywhere: it is not connected to any cable as it does not need any electricity.

**it** Follow è il tavolo regolabile in altezza che permette di trovare in modo facile, veloce e silenzioso la giusta posizione. La versione meeting con struttura in acciaio verniciato e piano tondo disponibile fino a 1600 mm di diametro è ideale per riunioni in spazi ufficio ma può essere utilizzato anche in aree meeting e zone di convivialità. Maniglia di regolazione dell'altezza in metallo.  
Follow Meeting può essere disposto liberamente nella stanza non avendo bisogno di alcuna alimentazione elettrica.

FOLLOW MEETING  
**monochromatic sit-stand table**  
tavolo regolabile in altezza monocromatico

**299MCAR**

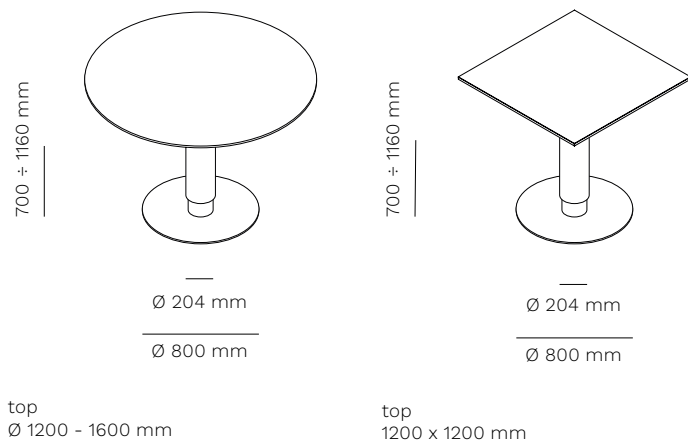

**Seal of Excellence from the European Union's 2020 Research and Innovation Programme.**  
Sigillo d'Eccellenza dal Programma di Ricerca e Innovazione dell'Unione Europea Horizon 2020.



**patented system**  
sistema brevettato



**adjustable height**  
altezza regolabile



**version with FSC® certified top**  
versione con piano certificato FSC®



**fast**  
veloce



**silent**  
silenzioso



**no electricity**  
no elettricità



<b>1 BASE</b> 1 BASE	<b>40 Kg</b>	<b>1 pc</b> 0,026 mc	<b>6 pcs /</b> 160 x 100 cm pallet
<b>1 UNDER-TOP CROSS</b> 1 CROCIERA	<b>15 kg</b>	<b>1 pc</b> 0,034 mc	
<b>1 COLUMN</b> 1 COLONNA	<b>41,2 kg</b>	<b>1 pc</b> 0,081 mc	<b>12 pcs /</b> EU pallet

# FOLLOW MEETING MONOCHROMATIC

## 299MCAR

# mara

### INCLUDED ACCESSORIES / ACCESSORI INCLUSI

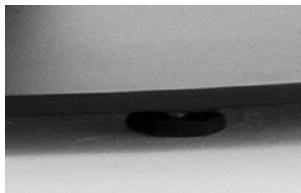

**foot levelers**  
piedini livellatori

### ACCESSORIES / ACCESSORI

**299MZ**

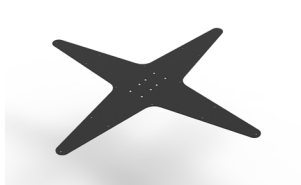

**counter-balance kit**  
(1 zavorra da 5 kg)  
counter-balance kit  
(1 x 5 kg ballast)

**511PLUS**



**top access with flip cover**  
passacavi con sportello

**511EPLUS**



**top access with multifunctional sockets**  
passacavi con prese multifunzione

**PASD60**



**multifunctional sockets**  
Ø 60 mm  
prese multifunzione  
Ø 60 mm

**PASD80**



**multifunctional sockets with wireless charging**  
Ø 80 mm  
prese multifunzione con ricarica wireless Ø 80 mm

**299ME**



**kit for electrification**  
kit per elettrificazione

**300**



**cpu holder**  
portaserver

**500DROLL**



**mobile storage system, on castors**  
cassettiera mobile su ruote

**VERTEBRE**



**Flexible cable management**  
Vertebra flessibile in rete

# FOLLOW MEETING MONOCHROMATIC

## 299MCAR

# mara

### FRAME / STRUTTURA

**powder coated steel**  
acciaio verniciato



**296**  
**textured**  
raggrinzato  
RAL 9010



**819**  
**textured**  
raggrinzato  
RAL 8019



**420**  
**textured**  
raggrinzato



**333**  
**textured**  
raggrinzato  
RAL 3003



**111**  
**textured**  
raggrinzato  
RAL 5011



**203**  
**textured**  
raggrinzato  
RAL 6003



**700**  
**textured**  
raggrinzato  
RAL 7000



**444**  
**textured**  
raggrinzato  
RAL 8004



**301**  
**textured**  
raggrinzato  
RAL 7044



**131**  
**textured**  
raggrinzato  
RAL 9006



**148**  
**textured**  
raggrinzato  
RAL 7016



**120**  
**textured**  
raggrinzato  
RAL 9005

### TOP / PIANO

**standard FENIX tops**  
piani standard in FENIX



**0754**  
Blu  
Fes



**0791**  
Giallo  
Evora



**0751**  
Rosso  
Jaipur



**0750**  
Verde  
Comodoro



**0032**  
Bianco  
Kos



**0720**  
Nero  
Ingo

**STANDARDS AND CERTIFICATES / NORME E CERTIFICATI**  
Resistance to scratching EN 438-2:2019 - CL.25 Class  $\geq 4$  •  
Resistance to staining EN 438-2:2019 - CL.26 Group 1 e 2: Class 5 Group 3: Class  $\geq 4$  • Resistance to dry heat (160°C/20') - EN 438-2:2019 - CL.16 Class 5 • Lightfastness (xenon arc) EN 438-2:2019 - CL.27 Grayscale classification  $\geq 4$  • Resistance to steam

EN 438-2:2019 - CL.14 Class 5 • Specular surface reflection ISO 2813 8 ÷ 16 a 85° Unità Gloss • Resistance to surface wear EN 438-2:2019 - CL.10 Rotation value IP  $\geq 200$  • Resistance to damp heat (100°C/20') - EN 438-2:2019 - CL.18 Class 5

**TOP / PIANO**

**standard colour and material effect laminate tops**

piani standard in laminato colore ed effetto materico



**white**  
bianco



**magnolia**



**light grey**  
grigio  
chiaro



**anthracite**  
antracite



**black**  
nero



**white marble \***  
marmo  
bianco



**graphite marble**  
marmo  
grafite



**black marble**  
marmo  
nero



**cement**  
cemento



**iron**  
ferro



**whitened oak**  
rovere  
sbiancato



**natural oak**  
rovere  
naturale



**grey oak warm**  
rovere  
grigio warm



**walnut**  
noce



**blue \***  
blu



**light blue \***  
azzurro



**powder \***  
cipria



**terracotta \***  
terracotta



**red \***  
rosso

\* finishes available only for Ø 1200 mm tops

\* finiture disponibili solo per piani Ø 1200 mm

**STANDARDS AND CERTIFICATES / NORME E CERTIFICATI**

Dimensional tolerance related to the thickness  $\pm 0,3$  mm • Dimensional tolerance related to the sizes  $\pm 5,0$  mm • Resistance to scratching EN 438-2:2016 Class 3 • Resistance to staining EN 438-2:2016 Group 1 e 2: Class  $\geq 4$  Group 3: Class  $\geq 4$  • Resistance to dry heat (160°C/20') - EN 438-2 Class 4 • Lightfastness (xenon arc) EN 438-2 Grayscale classification  $\geq 4$

• Resistance to steam EN 438-2 Class 4 • Resistance to surface wear EN 438-2 Rotation value IP  $\geq 150$  • Resistance to damp heat (100°C/20') - EN 438-2 Class 4

**standard colour, material effect and soft touch melamine tops**

piani standard in nobilitato colore, effetto materico e soft touch



**white**  
bianco



**magnolia**



**light grey**  
grigio  
chiaro



**anthracite**  
antracite



**black**  
nero



**whitened oak**  
rovere  
sbiancato



**natural oak**  
rovere  
naturale



**grey oak warm**  
rovere  
grigio warm



**walnut**  
noce



**T1 white**  
bianco



**T2 black**  
nero



**T6 brown**  
marrone



**T8 blue**  
blu



**cement**  
cemento



**iron**  
ferro

**STANDARDS AND CERTIFICATES / NORME E CERTIFICATI**

Dimensional tolerance related to the sizes  $\pm 5,0$  mm • Resistance to scratching 1,5 N • Resistance to cigarette burning 3 grade - moderate change in gloss level and/or moderate brown spots • Resistance to surface wear Rotation value IP  $< 50$  Rotation value WR  $< 150$  • Risk of breakage  $\geq 3$  group • Dimensional tolerance related to the thickness  $15 \leq X \leq 20$  mm :  $\pm 0,3$  mm X  $< 20$  mm :  $\pm 0,5$  mm • Resistance to staining  $\geq 3$  group

• Resistance to steam 4 grade - moderate change in gloss level and/or color • Surface imperfections Prolate imperfections:  $< 20$  mm/m Punctiform imperfections:  $< 2$  mm<sup>2</sup>/m<sup>2</sup> • Lightfastness (xenon arc)  $> 6$  group

**CLEANING AND MAINTENANCE / PULIZIA E MANUTENZIONE**

**STEEL / ACCIAIO**

**en** Our types of metals include: chromed metals and painted metals. Do not use acid or alkaline based cleaning products. Do not use detergents, steel wool, dishwashing detergents or the like. Sharp or pointed objects may damage the surface. Any hot or wet object may cause surface damage. Clean the surface regularly with a soft cloth to remove dust. To remove light dirt, use a soft cloth and a neutral household cleaner.

**it** Le nostre tipologie di metallo comprendono: metalli cromati e metalli verniciati. Non utilizzare prodotti per la pulizia a base acida o alcalina. Non utilizzare detergenti, lana di acciaio, detersivi per stoviglie o simili. Oggetti appuntiti o taglienti possono danneggiare la superficie. Qualsiasi oggetto caldo o bagnato potrebbe provocare danni alla superficie. Pulire la superficie regolarmente con un panno soffice per rimuovere la polvere. Per rimuovere lo sporco leggero utilizzare un panno soffice e un prodotto per le pulizie di casa neutro.

**CHROMED STEEL AND ALUMINIUM POLISHED / ACCIAIO CROMATO E ALLUMINIO LUCIDO**

**en** Do not use acid or alkaline based cleaning products. Do not use detergents, steel wool, dishwashing detergents or the like. Sharp or pointed objects may damage the surface. Any hot or wet object may cause surface damage. Clean the surface regularly with a soft cloth to remove dust. To remove light dirt, use a soft cloth and a neutral household cleaner

**it** Non utilizzare prodotti per la pulizia a base acida o alcalina. Non utilizzare detergenti, lana di acciaio, detersivi per stoviglie o simili. Oggetti appuntiti o taglienti possono danneggiare la superficie. Qualsiasi oggetto caldo o bagnato potrebbe provocare danni alla superficie. Pulire la superficie regolarmente con un panno soffice per rimuovere la polvere. Per rimuovere lo sporco leggero utilizzare un panno soffice e un prodotto per le pulizie di casa neutro.

**LAMINATE AND MELAMINE / LAMINATI E NOBILITATI**

**en** Laminates and melamine products guarantee high performance in terms of resistance to scratches, shocks and abrasions. Keep furniture away from direct sunlight; furniture in direct sunlight may tend to discolour over time. Do not use acid or alkaline based cleaning products. Sharp or pointed objects can damage the surface. Laminate and melamine furniture can be cleaned using a mixture of liquid soap and hot water. Rinse with cold water and dry with a paper towel or damp cloth.

**it** Laminati e nobilitati garantiscono alte prestazioni di resistenza ai graffi, agli urti e alle abrasioni. Mantenere i mobili lontani dalla luce diretta del sole; i mobili che si trovano alla luce diretta del sole potrebbero tendere a scolorire nel tempo. Non utilizzare prodotti per la pulizia a base acida o alcalina. Oggetti appuntiti o taglienti possono danneggiare la superficie. E' possibile effettuare la pulizia dei mobili in laminato e nobilitato usando una miscela di sapone liquido e acqua calda. Sciacquare con acqua fredda e asciugare con un tovagliolo di carta o un panno umido.

**STANDARD FENIX TOPS / PIANI STANDARD IN FENIX**

**en** Cleaning FENIX means cleaning its structure. You can do this with warm water. As FENIX is a strong material, you can also use any household cleaner – even solvents like acetone \* if needed. However, to avoid damaging the structure, don't scrub it with abrasive cream, a scouring pad or a hard brush; in the long-term, this might lead to a glossy spot on your matt surface. Instead, you can use a melamine sponge – also known as a magic sponge. As a final step, to avoid anything staying behind in the structure – whether that's dirt or residue from your cleaner – always rinse afterward with warm water and wipe dry with a clean cloth.

\* always follow safety instructions

**it** Pulire FENIX significa pulirne la struttura. Si può farlo, usando acqua tiepida. Poiché FENIX è un materiale resistente, si può utilizzare qualsiasi detergente per la casa, se necessario anche un solvente come l'acetone \*. Tuttavia, per evitare di danneggiare la struttura, è consigliabile evitare di strofinarla usando una crema abrasiva, una spugna abrasiva o una spazzola con setole dure; nel tempo, ciò potrebbe portare alla formazione di un'area lucida sulla superficie opaca. Si può piuttosto utilizzare una spugna in melamina, nota anche come spugna magica.

Come ultimo passaggio, per evitare la formazione di depositi nella struttura, che si tratti di sporco o residui del detergente, risciacquare sempre con acqua tiepida e asciugare con un panno pulito.

\* seguire sempre le istruzioni di sicurezza.

**TECHNICAL SPECIFICATION**  
299MCAR MONOCHROMATIC



> Follow Meeting Monochromatic has a height range of 460 mm.

> Follow Meeting Monochromatic can be used with table tops from 1200 mm to 1600 mm of diameter and table tops 1200 mm wide and 1200 mm deep.

> The table frame (Ø 800 mm) is designed for optimal operation in a range of weights (top weight + accessories weight) between 22 and 30 kg.

> Depending on the intended use of the table, carefully evaluate the weight of the table top to be assembled.

> If a lighter table top is to be installed or if the table is to work without additional weight, the “counter-balance kit” is able to reduce by 5 to 10 kg the upwards thrust allowing a correct functioning of the movement. A second counter-balance kit can be installed to reduce the weight by a further 5 kg.

For further information please contact our Customer Service.

Follow Meeting Monochromatic	min	max
height range (mm)	460	
frame height (mm)	700	1160
top diameter (mm)	Ø 1200	Ø 1600
table top width (mm)	1200	
table top depth (mm)	1200	
table top weight + accessories recommended weight (kg)	22	30
counter-balance kit *	5	10

\* optional

TOP WEIGHTS					TOP + CLIENT LOADING RECOMMENDED WEIGHT (kg)	
SINGLE TOP	Ø 1200 mm	Ø 1400 mm	Ø 1600 mm	1200x1200 mm	MIN	MAX
MELAMINE TOP 18/19 mm	14 kg	20 kg	25 kg	18 kg	22	30
MELAMINE TOP 25 mm	18 kg	25 kg	-	23 kg		
LAMINATE AND FENIX TOP 20 mm	17 kg	24 kg	-	22 kg		
LAMINATE AND FENIX TOP 27 mm	23 kg	-	-	29 kg		

**PLEASE NOTE: OBSERVE THE WEIGHTS INDICATED**

> A load, on the frame, exceeding the maximum weight indicated (top weight + accessories weight), causes a rapid lowering of the table top when unlocked.

> A load, on the frame, below the minimum weight indicated (top weight + accessories weight), causes an excessive upward thrust of the table when unlocked.

## INSTRUCTIONS FOR CORRECT USE

### ONLY IF NECESSARY:

A. Unscrew the nut (6a) and adjust the handle cable (6b): a clockwise rotation will loosen it, while a counter clockwise rotation will tighten it out. The adjustment is correct when the handle is neither loose nor rigid.

B. Secure the nut (6a) after adjusting the cable tension of the handle (6b).

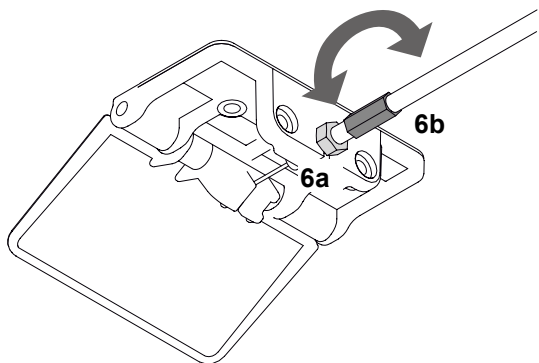

### DAILY USE:

1. Place one hand on the adjustment handle and the other hand on the same side of the table top, and operate the movement (fig. 1).
2. Using both hands, lift or lower the top to the desired height.
3. The table is easily adjustable.  
In case of difficult use, adjust the handles cable (see "only if necessary").
4. Once the desired height has been reached, stop the movement and release the handle.  
The table will automatically lock in the desired position.

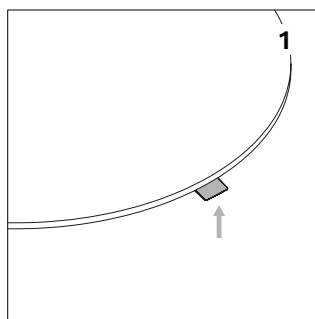

### ATTENTION

Any part of all components already assembled and supplied by the company cannot be disassembled unless this is done by Mara personnel. The assembly and disassembly of this table must be carried out by skilled operator following the instructions carefully.

**SPECIFICHE TECNICHE**  
299MCAR MONOCROMATICO

**mara**

> Follow Meeting Monocromatico ha un'escursione in altezza di 460 mm.

> Follow Meeting Monocromatico può montare piani da 1200 mm a 1600 mm di diametro e piani da 1200 mm di larghezza e 1200 mm di profondità.

> Il telaio del tavolo (Ø 800 mm) è progettato per un funzionamento ottimale in un intervallo di pesi (peso piano + pesi accessori) compresi tra i 22 e i 30 Kg.

> In base all'utilizzo previsto del tavolo, valutare attentamente il peso del piano da montare.

> Se è previsto il montaggio di un piano più leggero o non è previsto di caricare il piano di lavoro, l'accessorio "counter-balance kit" è in grado di ridurre da 5 a 10 kg la spinta verso l'alto permettendo il corretto funzionamento del movimento. Un secondo counter-balance kit può essere montato per ridurre di ulteriori 5 kg la spinta. Per maggiori informazioni contattare il Servizio Clienti.

<b>Follow Meeting Monocromatico</b>	min	max
<b>escursione altezza (mm)</b>	460	
<b>altezza telaio (mm)</b>	700	1160
<b>diametro piano (mm)</b>	Ø 1200	Ø 1600
<b>larghezza piano (mm)</b>	1200	
<b>dimensioni piano (mm)</b>	1200	
<b>peso piano + peso accessori (kg) consigliato</b>	22	30
<b>counter-balance kit * (kg)</b>	5	10

\* opzionale

<b>PESI PIANI</b>					<b>PIANO + CARICO CLIENTE PESO CONSIGLIATO (kg)</b>	
<b>PIANO SINGOLO</b>	Ø 1200 mm	Ø 1400 mm	Ø 1600 mm	1200x1200 mm	<b>MIN</b>	<b>MAX</b>
PIANO IN NOBILITATO SP 18/19 mm	14 kg	20 kg	25 kg	18 kg	<b>22</b>	<b>30</b>
PIANO IN NOBILITATO SP 25 mm	18 kg	25 kg	-	23 kg		
PIANO IN LAMINATO E FENIX SP 20 mm	17 kg	24 kg	-	22 kg		
PIANO IN LAMINATO E FENIX SP 27 mm	23 kg	-	-	29 kg		

**ATTENZIONE: ATTENERSI AI PESI INDICATI**

> Un carico sopra il telaio superiore al peso massimo indicato (peso piano + peso accessori) causa un veloce abbassamento del piano al momento dello sblocco.

> Un carico sopra il telaio inferiore al peso minimo indicato (peso piano + peso accessori) causa un veloce innalzamento del piano al momento dello sblocco.

## ISTRUZIONI D'USO

### SOLO SE NECESSARIO:

- A. Svitare il dado (6a) e regolare il cavo della maniglia (6b): una rotazione oraria lo allenterà mentre una rotazione antioraria lo tenderà. La regolazione è corretta quando la maniglia non risulta nè libera ne troppo dura.
- B. Fissare il dado (6a) una volta regolata la tensione del cavo.

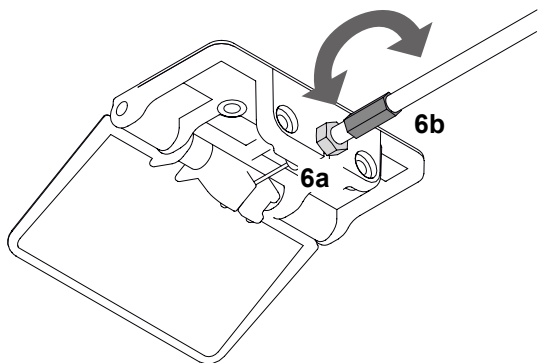

### USO QUOTIDIANO:

1. Posizionare la mano d'utilizzo sulla maniglia di regolazione e l'altra mano sullo stesso lato del piano e azionare il movimento (fig. 1).
2. Utilizzando entrambe le mani, sollevare o abbassare il piano all'altezza desiderata.
3. Il tavolo si regola facilmente.  
In caso di difficoltà nell'utilizzo, migliorare la regolazione del cavo della maniglia (vedi "solo se necessario").
4. Raggiunta l'altezza desiderata fermare il movimento e rilasciare la maniglia di regolazione. Il tavolo si bloccherà automaticamente nella posizione desiderata.

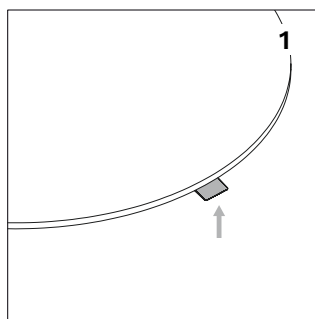

### ATTENZIONE

Ogni componente fornito già montato dall'azienda non può essere smontato in nessuna sua parte se non da personale Mara. Montaggio e smontaggio di questo tavolo deve essere effettuato da personale esperto seguendo attentamente le istruzioni.

## TOP ACCESS

PASSACAVI

511PLUS

# mara

### DESCRIPTION / DESCRIZIONE

**en Aluminium top access with flap. Black brush.**

**it** Passacavi in alluminio con spazzola nera.



1

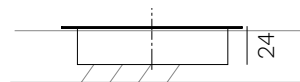
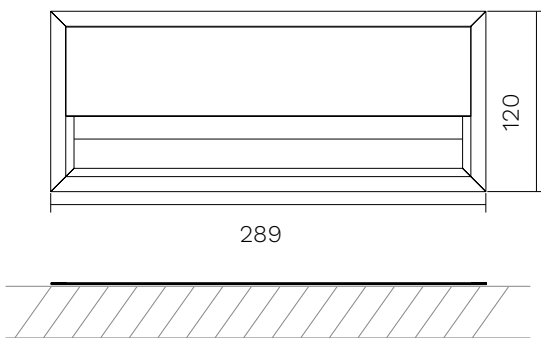

**All measurements are indicated in mm**  
Tutte le misure sono indicate in mm

### Surface cut-out area

Area di taglio della superficie

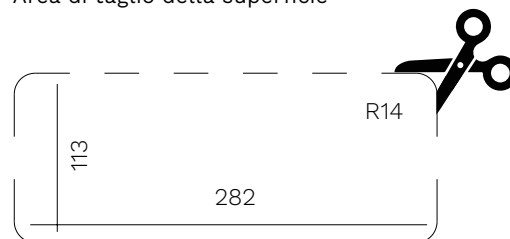

### COLOURS AVAILABLE / COLORI DISPONIBILI



**aluminium**  
alluminio



**black**  
nero



# TOP ACCESS WITH INTEGRATED POWER UNIT

## PASSACAVI CON MULTIPRESA INTEGRATA

# mara

511EPLUS

### DESCRIPTION / DESCRIZIONE

**en** Top access with integrated power unit for table tops max 30 mm thick, available in aluminium or black colour, 289x120 mm with 2 mt. power cable + 2 DE sockets + 2 USB 5V/2, 4A + 2 RJ45 sockets.

**it** Passacavo con multipresa integrata per piani tavoli spessore max 30 mm, disponibile nei colori alluminio o nero, 289x120 mm con 2 mt. di cavo di alimentazione + 2 presa DE + 2 prese USB 5V/2, 4A + 2 prese RJ45.



**Optional (on demand)\*:**  
Opzionali (su richiesta)\*:



\* dedicated quotation / quotazione dedicata

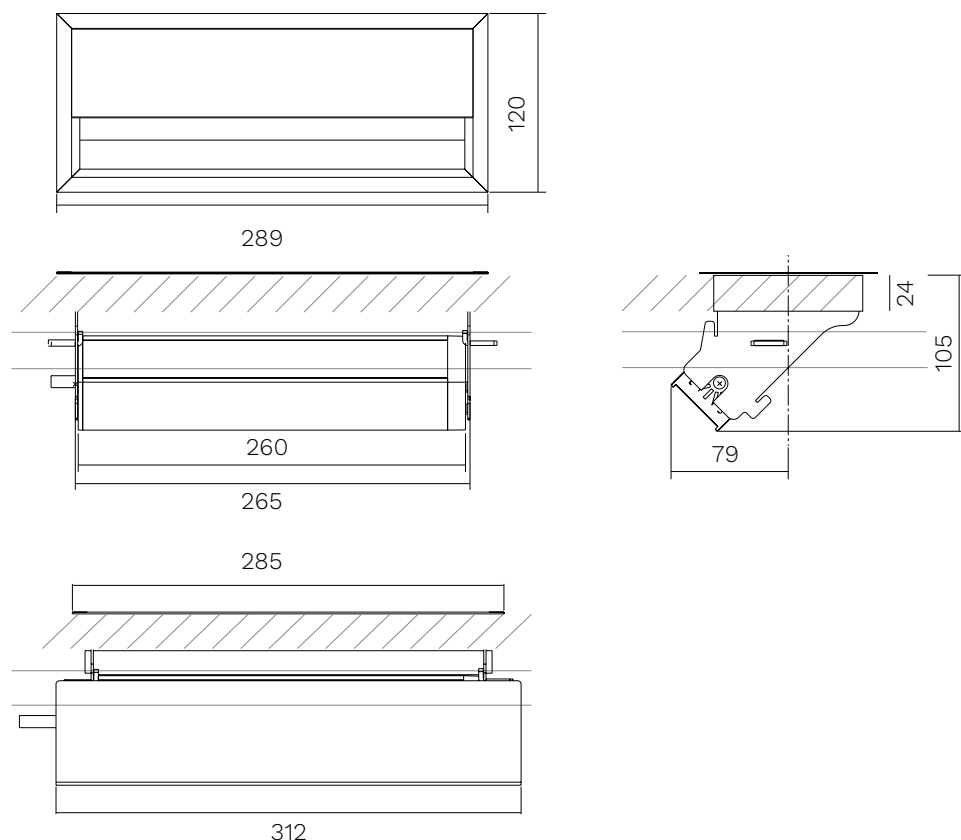

### Surface cut-out area

Area di taglio della superficie

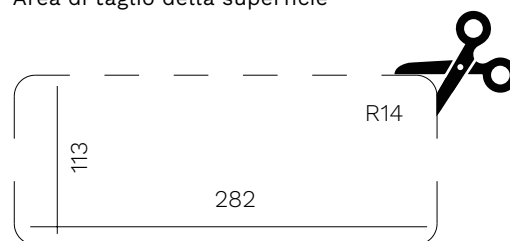

All measurements are indicated in mm  
Tutte le misure sono indicate in mm

### COLOURS AVAILABLE / COLORI DISPONIBILI

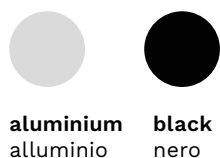

# TOP ACCESS WITH INTEGRATED MULTIFUNCTIONAL SOCKET

## PASSACAVI CON MULTIPRESA INTEGRATA

# mara

PASD60

### DESCRIPTION / DESCRIZIONE

**en** Top access round with integrated multifunctional socket for table tops, available in white or black colours, diameter 60 mm with 1,5 mt. power cable + 1 DE + 1 USB 5V/2, 4A socket.

**it** Presa multifunzione rotonda per piani tavoli, disponibile nei colori bianco o nero, diametro 60 mm con 1,5 mt. di cavo di alimentazione + 1 presa DE + 1 presa USB 5V/2, 4A.



**Optional (on demand)\*:**  
Opzionali (su richiesta)\*:

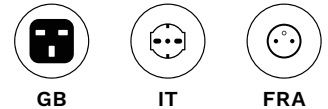

\* dedicated quotation / quotazione dedicata

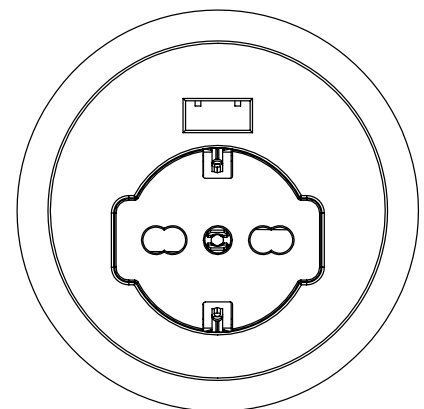
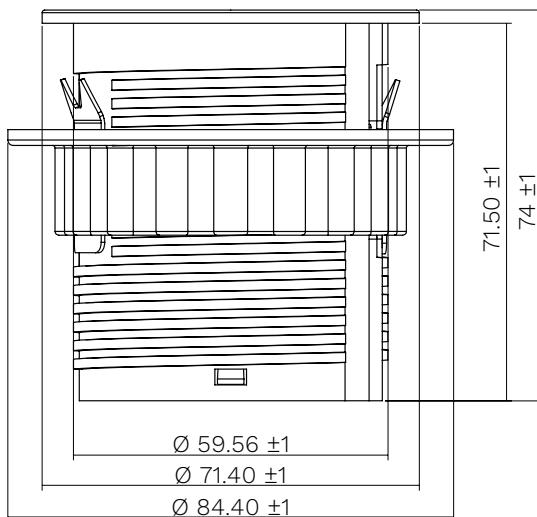

**Surface cut-out area**  
Area di taglio della superficie

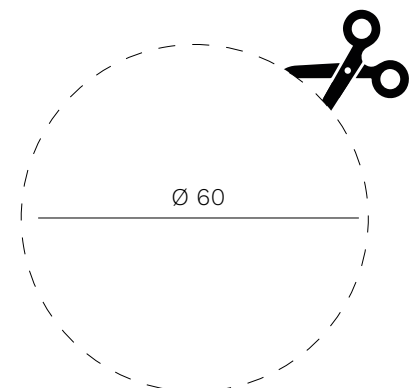

All measurements are indicated in mm  
Tutte le misure sono indicate in mm

### COLOURS AVAILABLE / COLORI DISPONIBILI



**white**  
bianco



**black**  
nero



# CABLE MANAGEMENT WITH INTEGRATED MULTISOCKET

## PASSACAPO CON MULTIPRESA INTEGRATA

# mara

PASD80

### DESCRIPTION / DESCRIZIONE

**en** Top access round with integrated multifunctional socket for table tops, available in white or black colours, diameter 80 mm with 2 mt. power cable + 1 DE + 2 USB 5V/2, 4A socket + 1 RJ45 (interchangeable). The inside of the cover is equipped with a wireless charger (usable only when open).

**it** Presa multifunzione rotonda per piani tavoli, disponibile nei colori bianco o nero, diametro 80 mm con 2 mt. di cavo di alimentazione + 1 presa DE + 2 prese USB 5V/2, 4A + 1 presa RJ45 (intercambiabile). L'interno del coperchio è provvisto di caricatore wireless (utilizzabile solo quando aperto).



wireless recharge

RJ45

DE

USB

1

**Optional (on demand)\*:**  
Opzionali (su richiesta)\*:



HDMI



EXIT



GB



IT



FRA

\* dedicated quotation and minimum order  
\* quotazione dedicata e minimo d'ordine

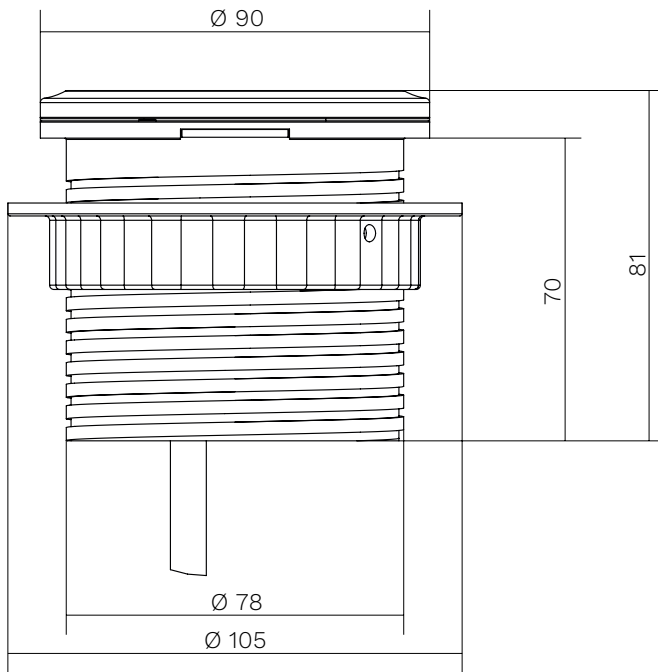

All measurements are indicated in mm  
Tutte le misure sono indicate in mm

### COLOURS AVAILABLE / COLORI DISPONIBILI



white  
bianco



black  
nero

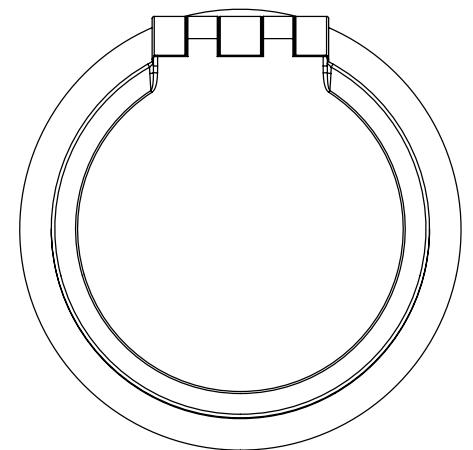

**Surface cut-out area**  
Area di taglio della superficie

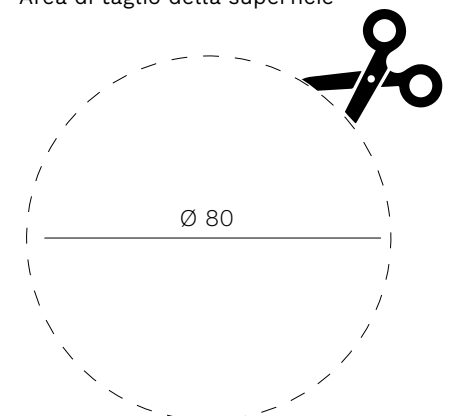

## FLEXIBLE CABLE MANAGEMENT

VERTEBRA FLESSIBILE IN RETE

VERTEBRE

# mara

### DESCRIPTION / DESCRIZIONE

**en** Flexible cable duct made of multifilament polyester, double slider zip, max. height 1300 mm, suitable for height-adjustable tables, complete with tabletop mounting plate and base with weight for greater stability

**it** Canalina flessibile realizzata in poliestere multifilamento, cerniera con doppio cursore, altezza max. 1300 mm, adatta a tavoli regolabili in altezza, completa di piastra di fissaggio al piano e base con peso per maggiore stabilità

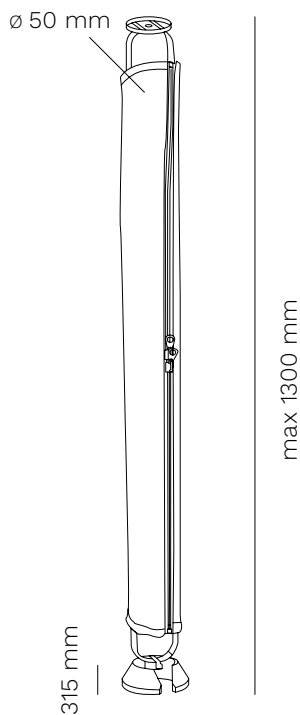

- Suitable for height-adjustable tables
- For table tops with a maximum height of 1300 mm
- Hinge with two sliders for opening from both the top and bottom
- Easy to attach to the table top with a single screw (included)
- Versatile thanks to the flexibility of the fabric

- Adatta a tavoli regolabili in altezza
- Per piani tavolo con altezza max. 1300 mm
- Cerniera con due cursori per apertura sia dall'alto che dal basso
- Fissaggio facilitato al piano tramite una sola vite (inclusa)
- Versatile grazie alla flessibilità del tessuto

### Flexible multi-filament polyester fabric

Tessuto flessibile in poliestere multifilamento



**Black**  
nero



**aluminium**  
alluminio



**white**  
bianco

**en** As it is always seeking to improve its products, the company reserves the right to modify or upgrade the products without prior notice, at any time. Colors should be considered purely indicative. Mara's Collections are worldwide protected by the industrial property right and patents.

**it** Mara, sempre alla ricerca del miglioramento dei propri prodotti, si riserva la facoltà di apportare modifiche costruttive e funzionali in qualsiasi momento senza alcun preavviso. I colori dei materiali sono da ritenersi puramente indicativi. Tutte le collezioni Mara sono protette nel mondo dal diritto di proprietà industriale e da brevetti registrati.