

HEDGE

Technical Specifications

HEDGE provides a versatile semi-static visual and acoustic barrier for privacy without disturbing the office layout. Easily moved, HEDGE can be adapted to suit a variety of work styles including private or collaborative task needs and will enhance a flexible work environment.



Product Data

SINGLE SCREEN

Product dimensions

Width (W)	1000 / 1200mm
Height (H)	1400 / 1600 / 1800mm
Foot	500mm

Structure

Plywood panels	32mm hoop pine plywood
Internal structure	Acoustic foam
External structure	Acoustic wall covering
Base	Steel foot with glides

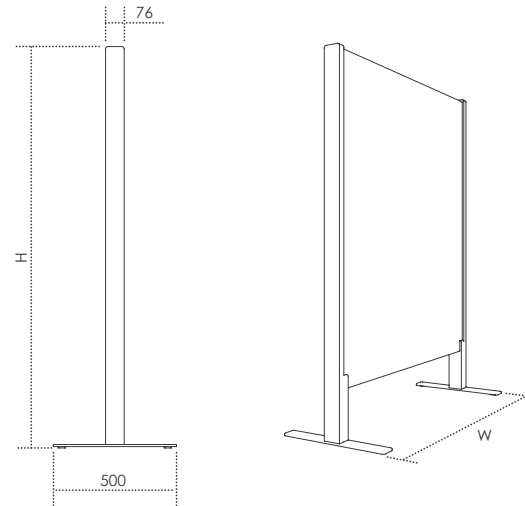

SINGLE SCREEN ON CASTORS

Product dimensions

Width (W)	1000 / 1200mm
Height (H)	1400 / 1600 / 1800mm
Foot	500mm

Structure

Plywood panels	32mm hoop pine plywood
Internal structure	Acoustic foam
External structure	Acoustic wall covering
Base	Steel foot with castors

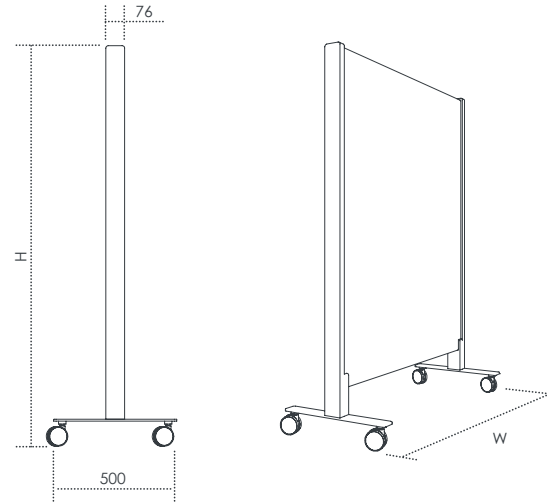

Product Data

DOUBLE SCREEN

Product dimensions

Width (W)	1400 / 1600 / 1800mm
Height (H)	1400 / 1600 / 1800mm
Foot	500mm

Structure

Plywood panels	32mm hoop pine plywood
Internal structure	Acoustic foam
External structure	Acoustic wall covering
Base	Steel foot with glides

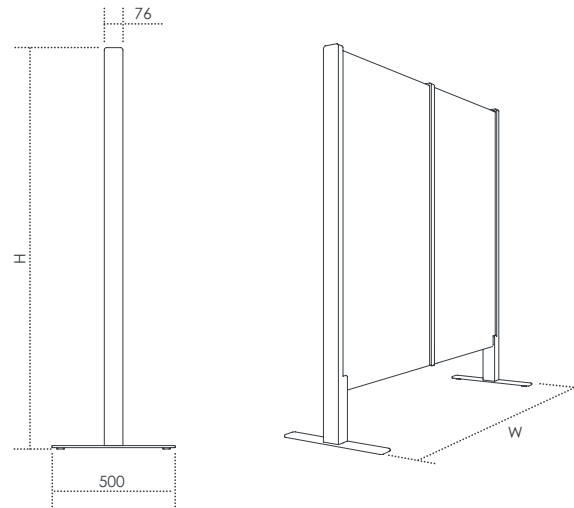

CORNER SEGMENT (single or double)

Product dimensions

Width narrow screen (W)	1000 / 1200mm
Width wide screen (W)	1400 / 1600 / 1800mm
Height (H)	1400 / 1600 / 1800mm
Foot	500mm

Structure

Plywood panels	32mm hoop pine plywood
Internal structure	Acoustic foam
External structure	Acoustic wall covering
Base	Steel foot with glides

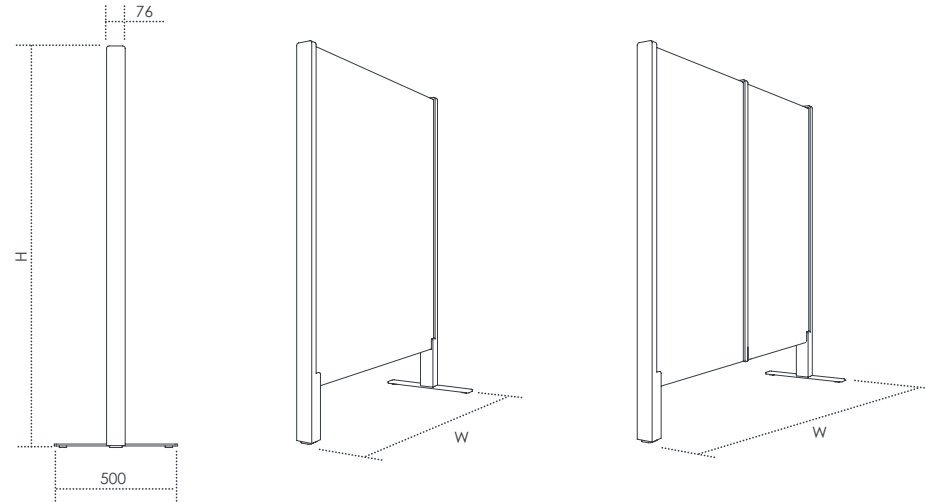

Product Data & Finishes

Product data - common for all products

PET

Composition	100% PET, 60-68% recycled
Sustainability	Greentag certified. Greenrate level: A
VOC emission	<0.004mg/m ² /hr

Cleaning

PET / Upholstery	Refer to product care and maintenance guide
Timber	Refer to product care and maintenance guide

Timber finishes

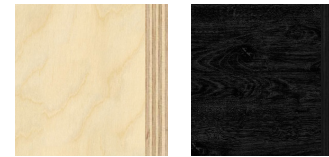

Natural

Black Stain

Acoustic wall covering finishes

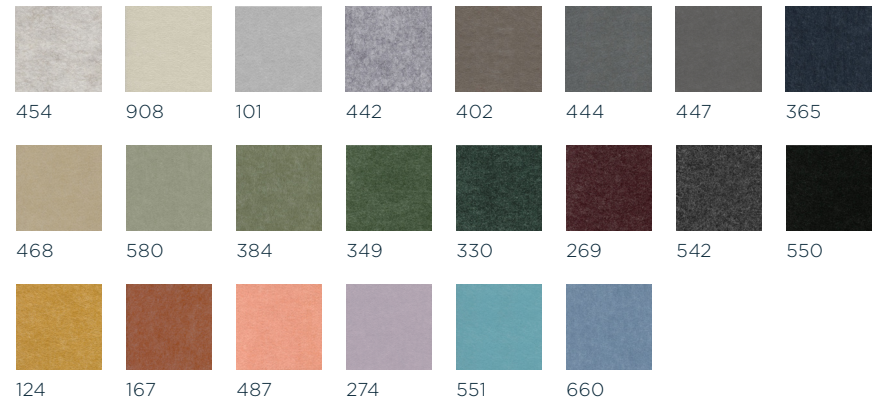

*Contact Square-Bear Acoustics for custom colour options.

SQUARE BEAR

© Copyright 2021

All Rights Reserved

HEAD OFFICE

Unit 6/80 Jemma Road, Prestons

New South Wales 2170, Australia

P: +61 (0)2 9189 1444

sales@square-bear.com

SYDNEY SHOWROOM

Level 3/140 William Street, Woolloomooloo

New South Wales 2011, Australia

www.square-bear.com