

OWWI

— By arnau-reyna studio —



The design of **OWWI** conveys at first glance its simplicity, versatility, formal charge, visual recognition and warmth, are the concepts that define this armchair of great comfort and cosy seating for its enveloping backrest.

The exterior upholstery with its wrinkles, results in the W that forms its name, generating a piece of great quality and sophistication, which combined with its structure that embraces the piece gives it the perfect balance.



ACTIU

www.actiu.com

Design goes beyond aesthetics: innovation, space and furniture go hand in hand to create environments that are friendlier, more comfortable and more motivating for people: environments that are more dynamic, fresh, creative, ergonomic and functional.

A business philosophy in which design is part of our DNA, as we apply it to every facet of the company: products, architecture, projects, brand, communication, work spaces ...



Model	OWWI · Medium backrest	
Model reference	Individual model- 1 pax	Twin model - 2 pax
Seat and Backrest	Variable seating foam densities, for non-operational environments (upholstered with inner wadding). Outer foams 30Kg extra hard Inner foam 30Kg soft Lumbar foam 20Kg super soft Outer backrest wadding 200 gr Seat and backrest padding 300 gr Aesthetic uniqueness. Upholstery with Ø10 mm piping and design with dynamic wrinkles.	
Internal Structure	Backrest frame made of 25mm thick pine wood structures, seat in 25mm section MDF and armrests made of 20mm thick MDF. The frames are joined to each other and to the metal frame by means of M8 screws.	
Structure/Base	Structure made of hot-rolled cylindrical steel tube Ø20mm and e=2 mm. with 90 micron thick epoxy paint coating.	
Supports	Polypropylene (P.P.) black with anti-slip felt.	
Measures <small>*según UNE-EN 1335-1</small>	<p>Total Measures: Height: 720 mm Width: 840 mm Depth: 720 mm Seat Measures: Height: 450 mm Width: 520 mm Depth: 565 mm</p>	<p>Total Measures: Height: 720 mm Width: 1435 mm Depth: 720 mm Seat Measures: Height: 450 mm Width: 1120 mm Depth: 555 mm</p>

Structure

Steel













































TEXTURED WHITE













TEXTURED BLACK

Fabrics

OPTION 01		
OUTSIDE FABRIC	Fabric AE	 AE16  AE92  AE69  AE44
INSIDE FABRIC	Fabric BB	 BB00  BB00  BB00  BB00
OPTION 02		
OUTSIDE FABRIC	Fabric CM STEP (Plain)	 CM16  CM92  CM12  CM76  CM62  CM58  CM46  CM90  CM91  CM77  CM93
INSIDE FABRIC	Fabric CM STEP MELANGE (Spotted)	 CM14  CM22  CM19  CM17  CM63  CM10  CM49  CM20  CM89
OPTION 03		
OUTSIDE FABRIC	Fabric CM STEP MELANGE (Spotted)	 CM14  CM22  CM19  CM17  CM63  CM10  CM49  CM20  CM89
INSIDE FABRIC	Fabric CM STEP (Plain)	 CM16  CM92  CM12  CM76  CM62  CM58  CM46  CM90  CM91  CM77  CM93
OPTION 04		
OUTSIDE FABRIC	Fabric CM STEP (Plain)	 CM16  CM92  CM12  CM76  CM62  CM58  CM46  CM90  CM91  CM77  CM93
INSIDE FABRIC	Fabric AM (Spotted)	 AM89  AM27  AM20  AM52  AM11
OPTION 05		
OUTSIDE FABRIC	Fabric AM (Spotted)	 AM89  AM27  AM20  AM52  AM11
INSIDE FABRIC	Fabric CM STEP (Plain)	 CM16  CM92  CM12  CM76  CM62  CM58  CM46  CM90  CM91  CM77  CM93

Weight and Volume // Ecodesign

OWWI								
MODEL	Packs	Weight	Volume	Materials Recycled materials	Production Aluminium, steel and wood	Transport Package and thinner free	Use To clean and maintain	Disposal Recyclable materials
								
				High	100%	100%	Very Easy	Alto
				High	100%	100%	Very Easy	Alto

Materials: Maximum use of materials to eliminate and minimize scraps. Use of recyclable and recycled materials in those components that do not affect the functionality and durability.
Production: Maximum optimization of energy use. Minimal environmental impact. Last generation technological systems. Zero discharge of wastewater. No VOC coatings. Processes free of heavy metals, phosphates, OC and COD.
Transport: Detachable systems. Volumes that facilitate the optimization of space. Maximum reduction of energy consumption by transport.
Use: Quality and warranty. Long lasting. Replacements available.
Disposal: Waste reduction. Supplier-manufacturer packaging reuse system. Components are easy to be separated. Inks in packaging are water-based, without solvents.

Standards

OWWI has passed tests done in our technical department as well as the tests done in AIDIMME the Technological Institute for furniture. The tests correspond to:

Standard	Description

Certificates

The different programmes get points in different environmental categories to get the LEED certificate or WELL certificate (sustainability, material and resources, water, energy and atmosphere, inner environment quality, innovation and design).



OWWI



ACTIU

OWWI

by Arnau Reyna



Sitting with **WOW** effect

OWWI is an icon recognisable to the touch and to the eye. Its design conveys simplicity, formal charge and versatility to define an armchair that stands out for its enveloping backrest. The characteristic wrinkles of its upholstery draw the Ws that give rise to its name and generate a welcoming sensation of embrace at every sitting position. Its high formal charge and its aesthetic warmth allow the sets formed by the armchairs and the two-seater sofas of the OWWI series to endow any space with sophistication.

OWWI es un icono reconocible al tacto y a la vista. Su diseño transmite sencillez, carga formal y versatilidad para definir un sillón que destaca por su envolvente respaldo. Las características arrugas de su tapicería dibujan las W que dan origen a su nombre y generan una acogedora sensación de abrazo en cada postura sentada. Su alta carga formal y su calidez estética permiten que los conjuntos formados por las butacas y los sofás de dos plazas de la serie OWWI doten de sofisticación cualquier espacio.

by ARNAU REYNA

“We want to create
future design icons”



A+R designs products that connect with the user and the spaces they inhabit. A+R starts with simple ideas that evolve throughout the design process. Timeless pieces that are not influenced by passing trends. A+R believes in design as a strategy, an intangible tool that is a fundamental pillar for companies as an engine of productivity and growth. “Design is not just having a good idea, but a criterion with which to draw the business roadmap”.

A+R diseña productos que conectan con el usuario y los espacios que habita. A+R parte de ideas sencillas que evolucionan a lo largo del proceso de diseño. Piezas atemporales que no se dejan influir por tendencias pasajeras. A+R cree en el diseño como estrategia, una herramienta intangible que es un pilar fundamental para las empresas como motor de productividad y crecimiento. “El diseño no es sólo tener una buena idea, sino un criterio con el que trazar la hoja de ruta empresarial.”

A+R conçoit des produits qui s'associent à l'utilisateur et aux espaces qu'il habite. A+R part d'idées simples qui évoluent tout au long du processus de conception. Des pièces intemporelles qui ne sont pas influencées par des tendances passagères. A+R considère le design comme une stratégie, un outil intangible qui constitue un pilier fondamental pour les entreprises en tant que moteur de productivité et de croissance. “Le design n'est pas seulement une bonne idée, c'est un critère qui permet de tracer la feuille de route de l'entreprise.”

A+R entwirft Produkte, die sich mit dem Benutzer und den von ihm bewohnten Räumen verbinden. A+R beginnt mit einfachen Ideen, die sich im Laufe des Designprozesses weiterentwickeln. Zeitlose Stücke, die nicht von vorübergehenden Trends beeinflusst werden. A+R glaubt an Design als Strategie, ein immaterielles Werkzeug, das ein grundlegender Pfeiler für Unternehmen als Motor für Produktivität und Wachstum ist. “Design ist nicht nur eine gute Idee, sondern ein Kriterium, mit dem man den Fahrplan für das Unternehmen erstellen kann”.





WOW







Investing in new hybrid spaces that enhance both the physical and emotional wellbeing of people is essential to create environments in which to connect with our loved ones... or simply disconnect.

Invertir por nuevos espacios híbridos en los que potenciar tanto el bienestar físico como emocional de las personas resulta fundamental para crear ambientes en los que conectar con los nuestros... o sencillamente desconectar.

Il est essentiel d'investir dans de nouveaux espaces hybrides qui améliorent le bien-être physique et émotionnel des personnes afin de créer des environnements dans lesquels nous pouvons nous connecter avec nos proches... ou simplement nous déconnecter.

Investitionen in neue hybride Räume, die sowohl das physische als auch das emotionale Wohlbefinden der Menschen fördern, sind unerlässlich, um Umgebungen zu schaffen, in denen wir mit unseren Lieben in Kontakt treten können... oder einfach nur abschalten können.



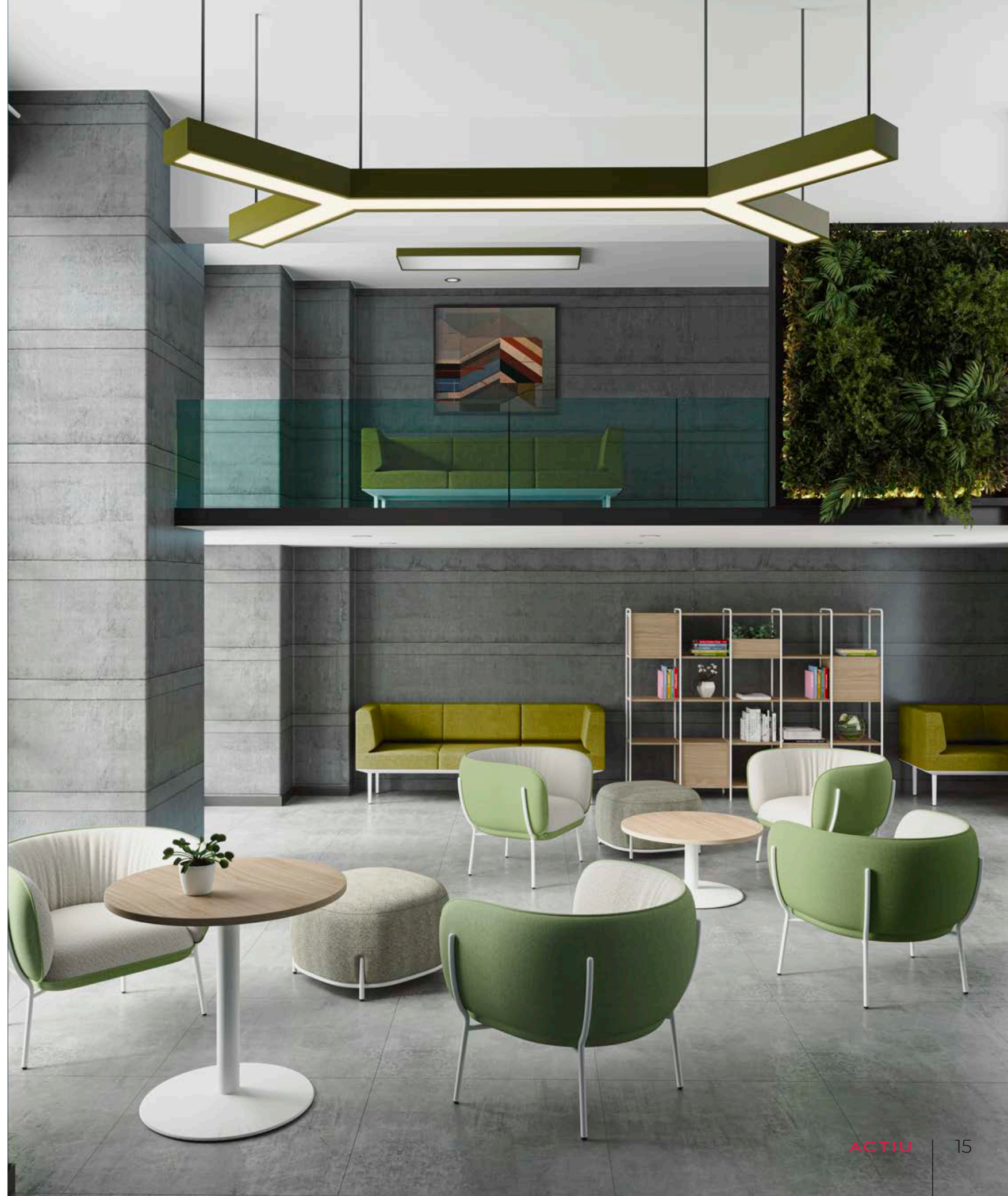
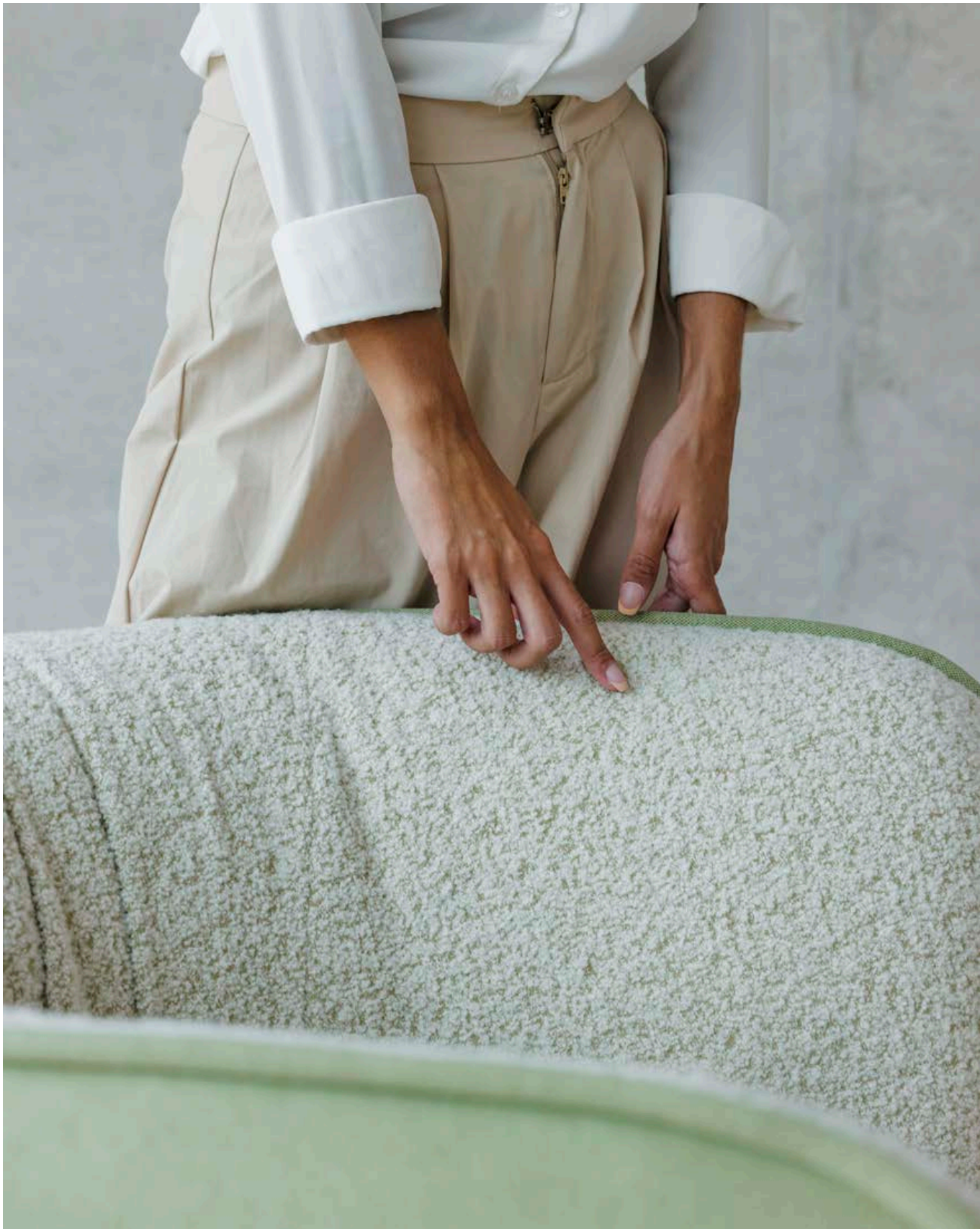



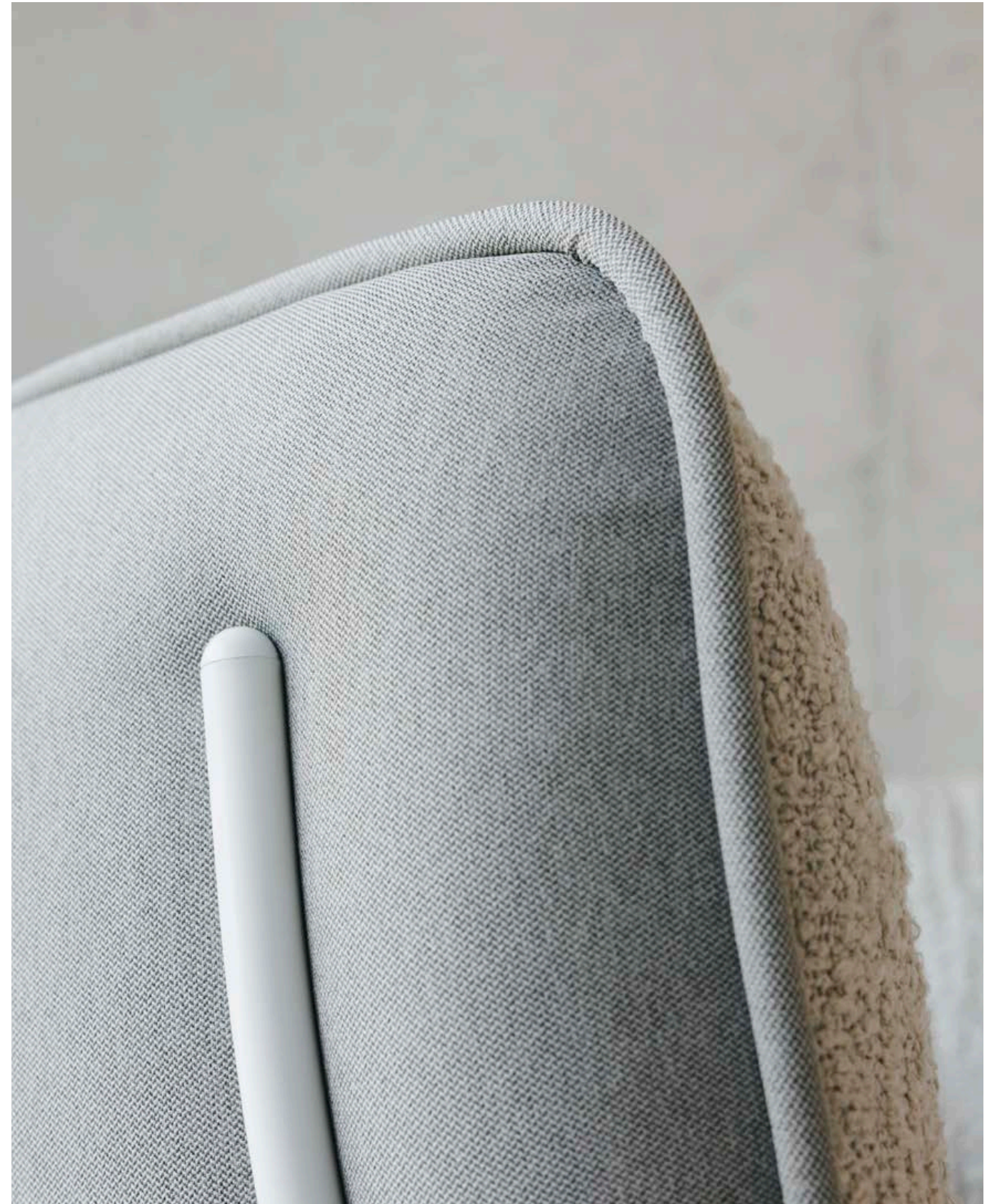



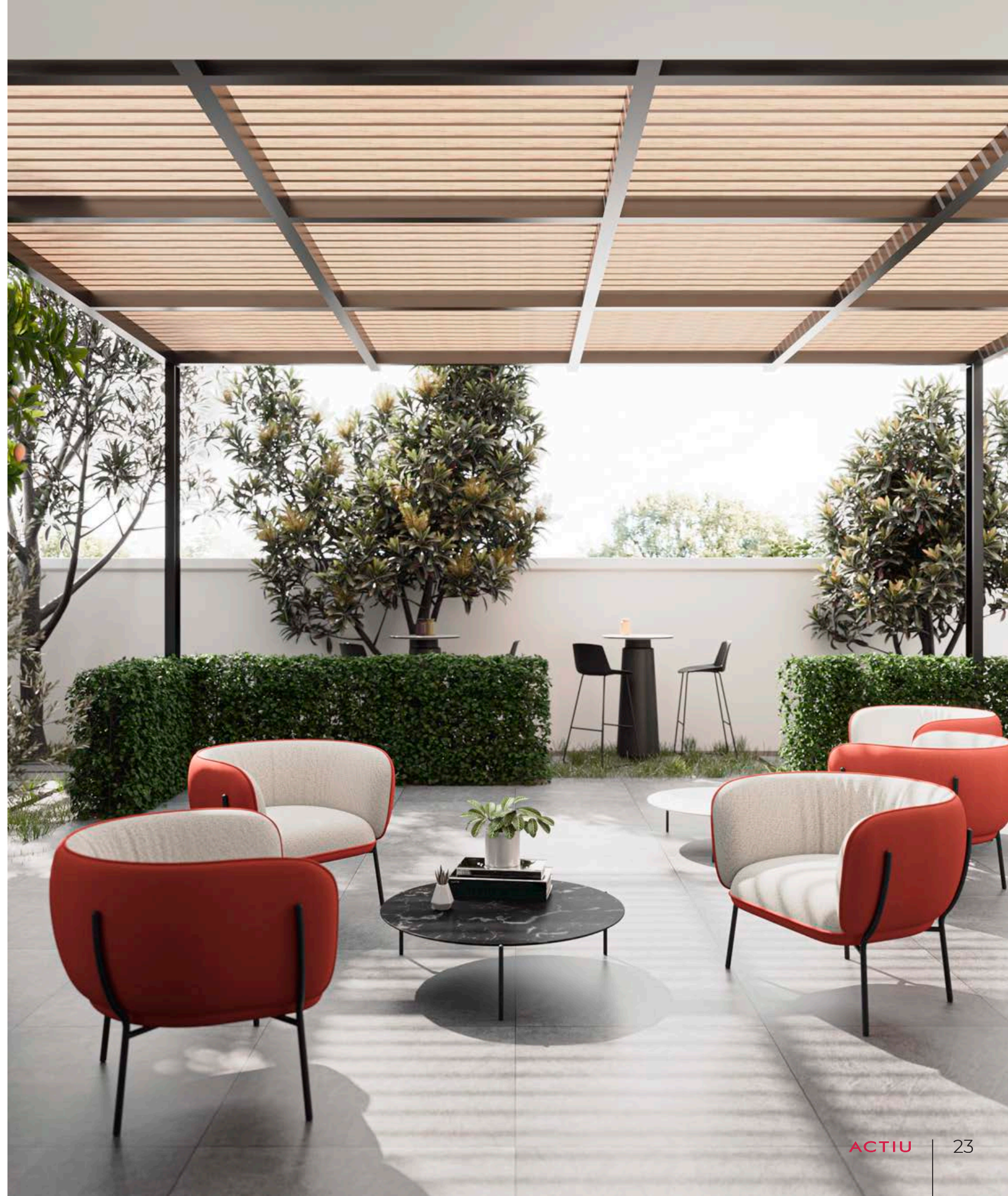

TECHNICAL FEATURES

Información técnica

El tapizado exterior con sus arrugas, da como resultado la W que conforma su nombre, generando una pieza de gran calidad y sofisticación, que combinado con su estructura que abraza la pieza le aporta el equilibrio perfecto.

The exterior upholstery with its wrinkles, results in the W that forms its name, generating a piece of great quality and sophistication, which combined with its structure that embraces the piece gives it the perfect balance.

Le revêtement extérieur, avec ses plis, donne le W qui forme son nom, générant une pièce de grande qualité et de sophistication, qui, combinée à sa structure qui englobe la pièce, lui donne l'équilibre parfait.

Die äußere Polsterung mit ihren Falten, gibt als Ergebnis das W, das seinen Namen bildet, wodurch ein Stück von großer Qualität und Raffinesse, die mit seiner Struktur, die das Stück umarmt, gibt es die perfekte Balance.



EIDOS TABLES / MESAS

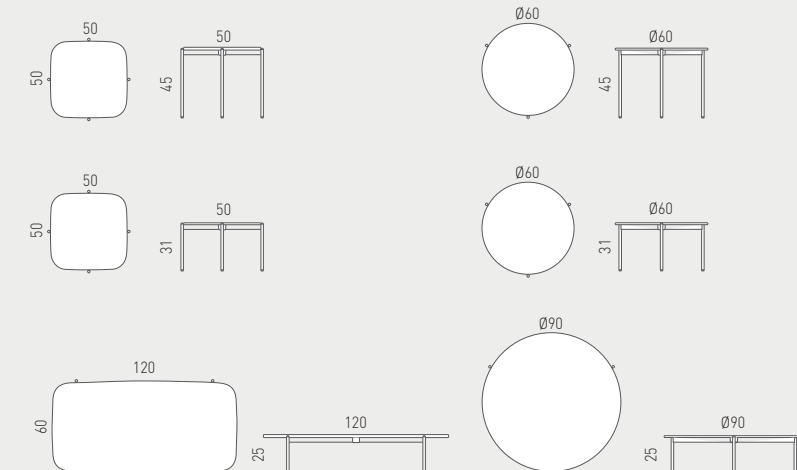

ACTIU TECHNOLOGY PARK

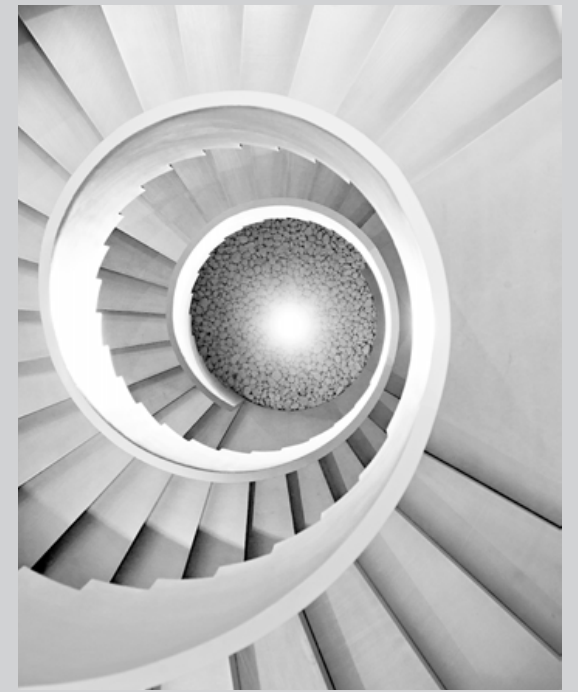

DESIGN & ARCHITECTURE

Space management and design
Products. Own patents
Communication

SUSTAINABILITY

Sustainable production
Product. Eco-design
Services, efficient logistics system
Actiu Technology Park, certified LEED® Platinum & WELL Platinum

MANUFACTURER

We are manufacturers
Domain raw materials and processes
Technology and Innovation
Standardized and specific solutions

GLOBAL COVERAGE

Presence in more than 90 countries
Global equipment solutions. Corporate, Health, Education, Contract, Transport.



ACTIU, National Design Award 2017
ACTIU, Premio Nacional de Diseño 2017

ACTIU: 50 YEARS DESIGNING PUBLIC SPACES AND WORKSPACES.

Actiu is an industrial company working within the installation sector and specialising in the manufacture of furniture. Actiu's flexibility and productive capacity enable the company to carry out comprehensive equipment projects worldwide, providing solutions that favour the wellbeing of people.

ACTIU, 50 AÑOS DISEÑANDO ESPACIOS PÚBLICOS Y DE TRABAJO.

Actiu es una empresa con una trayectoria industrial en el sector de la instalación, especializada en la creación de mobiliario, cuya flexibilidad y capacidad productiva permite desarrollar proyectos de equipamiento global a nivel internacional aportando soluciones que ofrezcan el bienestar de las personas.

ACTIU, 50 ANS DE CONCEPTION D'ESPACES PUBLICS ET DE TRAVAIL.

Actiu est une entreprise dotée d'un parcours à caractère industriel dans le secteur de l'installation, qui se spécialise dans la création de mobilier, et dont la flexibilité et la capacité de production permettent de développer des projets d'équipement global à un niveau international, tout en apportant des solutions qui puissent offrir du bien-être aux personnes.

ACTIU, 50 JAHRE DESIGN UND PRODUKTION VON MÖBELN FÜR ÖFFENTLICHE EINRICHTUNGEN UND ARBEITSRÄUME.

Unsere ständige Forschung, Weiterentwicklung, Flexibilität und Erfahrung ermöglichen es uns, Projekte im privaten und öffentlichen Bereich der verschiedensten Sektoren auf nationaler und internationaler Ebene durchzuführen. Stillstand ist uns fremd. Uns treibt das Bedürfnis an, näher an den Menschen zu sein und Lösungsmöglichkeiten zu entwickeln, die den Endnutzern Wohlgefühl bieten.

CERTIFICATES AND REFERENCES

ACTIU products fulfill all demands about management, quality and sustainability to provide extra value to the projects using recycled materials to get the recyclable final product.



Actiu, the first industrial company in the world to obtain the WELL v2 and LEED Platinum Certification



ACTIU reserves the right to carry out technical, dimensional and finishing modifications that it considers appropriate with respect to the information detailed in this document, so please check before confirming your orders.

ACTIU se reserva el derecho de llevar a cabo las modificaciones técnicas, dimensionales y de acabados que estime conveniente respecto a la información detallada en este documento, por el que se ruega verificación antes de confirmar sus pedidos.

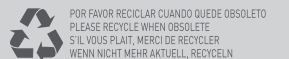



www.actiu.com