



Square  
Bear

FREE YOUR MIND

# WELLBEING IN THE WORKPLACE

Creating a healthy workplace plays an important and active role in maintaining mental health and well-being that results in benefits for both employer and employee. A well designed workplace supports individual work styles and leads to a reduction in absenteeism, increased employee engagement, and improved productivity. These important factors create positive organisational culture and a successful business outcome.

Reducing mental strain assists to protect against negative factors that impact on an individual's performance. Treating employee health as a primary consideration of business operations creates a work environment of happier, healthier employees and supports the engagement of a productive workforce.







# SQUARE BEAR

Square Bear is committed to creating products that increase a state of well-being. We are an Australian owned business, and our product designs support the need for work environments that allow people to think, focus, find mental peace, and support physical mobility and movement. Ultimately, we aim to increase productivity by supporting biophilic design styles for the workplace that can enhance employee well-being.

We create unique products to suit a variety of work styles. We focus on designing products that decrease distraction, stress, noise levels, and other negative influences. We understand the benefits of quiet workspaces for both individual and collaborative work styles and the requirement for sustained personal health while at work.

We believe that if you feel better, you work better.

# RESEARCH & DESIGN

Our talented R+D team design products that reflect our core value of enhancing workplace well-being. Our creative design hub and manufacturing facilities sit side by side, allowing our designers to constantly adapt and pursue new ideas that satisfy the ever-changing nature of the workplace. All aspects of production are considered throughout the design process including how the product will be used, how it looks, thoughtful selection of materials, manufacturing requirements, ease of installation and most importantly, the experience for the user.

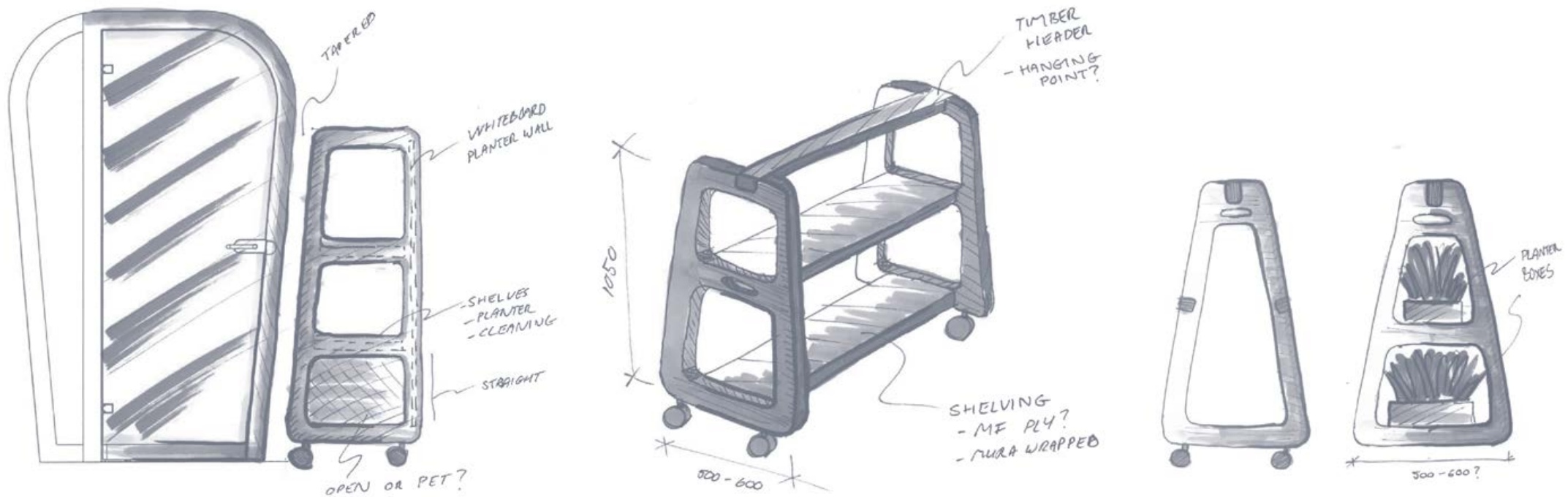

# WHY ENHANCE THE WORKPLACE?

Different work styles require different work spaces. Providing options for areas to work on individual and collaborative tasks also provides options for an improvement in focus, output, and satisfaction. Needs vary from person to person, task to task. Square Bear is aware that by creating an environment that offers flexibility, personal requirements can be satisfied, and greater productivity levels will be achieved. Some people like to work in busy environments, some people need to remove themselves from the distraction, and everyone needs a combination of both options for different projects, tasks, and work styles at different times. Square Bear products support task performance for different workstyles, individual preferences, and task requirements.





# ACOUSTICS, PEACE, AND PRIVACY

Finding peace in a busy environment can be difficult. Finding peace in a RETREAT pod is easy. Reducing noise can reduce distraction and enhance focus and well-being. Square Bear products aim to reduce work-related stress by offering a quiet space for individuals to retreat into when they need to find peace or privacy. Ideal for one person to escape the noise, or to gain focus for a team meeting and collaborative project, RETREAT provides an option for all quiet-time requirements. The short-term benefits of stress reduction can increase happiness and productivity, the long-term benefits can reduce absenteeism, conflict, and dissatisfaction. Retreat provides a reduction in noise and an improvement in mental well-being.



# OUR PRODUCTS IN THE WORKPLACE

Creating a layout to suit organisational needs considers all aspects of understanding how people interact and perform activities in the workplace. Square Bear products have been designed to provide flexibility. By combining various sizes of the RETREAT pods, a workspace will support meetings of various sizes, quiet work zones, private places for phone calls and thought processing, and a variety of activity areas with mobile whiteboards, bench seats, shelving, and planters. Easily adapted to the day's demands or the task requirements, employees can quickly move from meeting space into break-out zone and back again. RETREAT can be placed together in clusters, against walls, or in open plan areas to form a division between one zone and another. Using mobility and flexibility, employees can focus, meet, collaborate, and recharge their minds with ease.

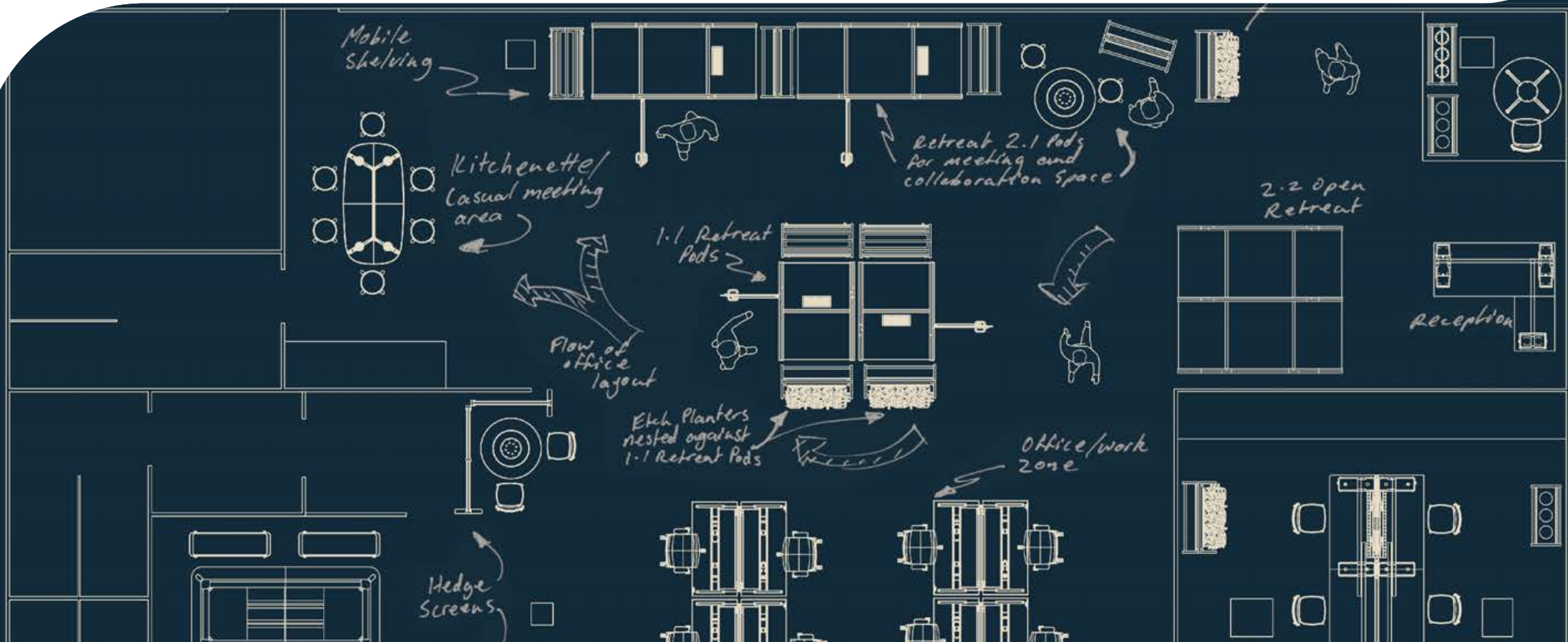





# SUSTAINABILITY

We are continually striving to achieve best-practice for social responsibility and environmental policies.

From the selection of materials to our supply chain choices, through to understanding energy efficiency and making an investment in respectful social choices, we aim for transparent communication, good judgement, and the role of taking responsibility for developing a better world.

Square Bear works with an independent consultant to obtain appropriate certification and is dedicated to complying with environmental standards and meeting human rights best practice. We are currently in the process of becoming a signatory to the UN Global Compact to demonstrate our commitment to address human rights, labour rights, environmental compliance, and anti-corruption.

Supply-chain due diligence is carried out for all components of production and is continually reviewed for updates. Square Bear implement ethical decision making for the benefit of all stakeholders while making a commitment to continually review and improve processes, production, and strategic direction.

We plan to act responsibly and to be transparent in all our sustainability communication.





PRODUCT RANGE



# RETREAT

This innovative private workspace is designed with an ergonomic tapered form inspired by the contour of the human body to give you more head space to breath, think, and work in peace.

Each product allows for modular design and is finished to a high standard with environmentally sourced materials. Acoustic materials are used both on the inside and outside of RETREAT pods, with additional acoustic baffles in between the walls to maximise acoustic performance. Highly functional, exceptionally comfortable, and acoustically private, RETREAT suits any workplace layout to provide quiet workspaces and unique structure. RETREAT comes without a floor base to allow for all users to enter the space without hinderance.

Dual vents and fans circulate air throughout RETREAT from both the base and top. This allows for an increase in oxygen availability to maximise comfort for the user. The fans and a light sensor are automatically controlled on entry and exit of the pod.

All enclosed RETREAT pods provide internal power and data options for a fully integrated plug and play solution, USB A and/or C ports are available on request. Depending on building and fire regulation requirements, RETREAT has been designed to provide access for a sprinkler system, smoke detector and alarm to be installed in coordination with individual project engineering specifications. This option can be linked to mechanical services within the workplace.

RETREAT is available with a rear glass panel, printed glass or full PET back on all models.



# RETREAT 1.0

## Technical Specifications

Designed for a private and peaceful drop in space to make a phone call, attend a virtual meeting, or focus on a task, RETREAT 1.0 is traditional in its rectangular geometry and fits neatly into any office space, coordinating with the complete RETREAT range to offer flexibility for workplace design. Standard features include comfortable ventilation, a fixed or drop-down table top, and a built in dimmable VC light that allows the user to create cool to warm skin tones as desired during virtual meetings.



### VENTILATION

Low noise, sensor-controlled ventilation system with constant air exchange via top and base outlets with internal fan systems.



### ENVIRONMENTAL DATA

60% recycled content to PET.  
Sustainably sourced timber FSC timber available on request.



### SERVICES

Seamless mechanical services integration with allowances for a sprinkler and smoke detector.



### VC LIGHT

Dimmable touch activated



### PERFORMANCE

Acoustic materials used for internal and external surfaces provide ambient noise reduction and minimise noise reverberation from the surrounding office.



### ACCESS

RETREAT sits flush on the floor with a rubber seal for acoustic protection, there is no step or floor base to impede entry.



### PLUG AND PLAY

Quick connection to mains power using standard sockets.



### WARRANTY

7 year structural warranty.



### INSTALLATION

RETREAT 1.0 requires 2 men for 2-3 hours.



Square  
Bear

RETREAT 1.0  
TECHNICAL SPECIFICATIONS

sales@square-bear.com  
www.square-bear.com

# PRODUCT DATA

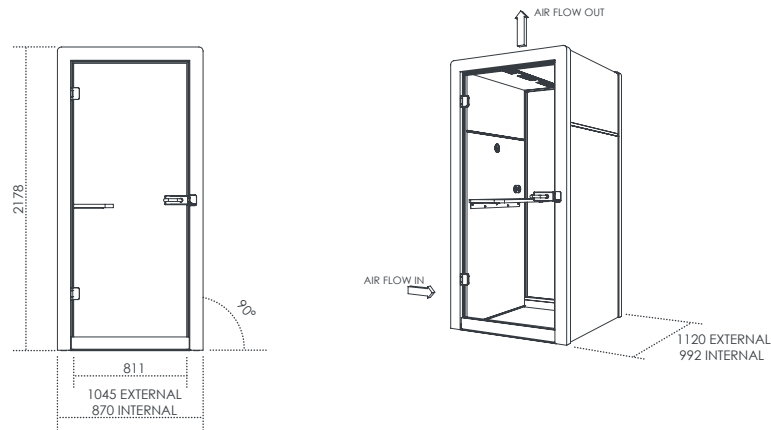

## Product dimensions

External dimensions	1045W x 1120D x 2178mmH
Internal dimensions	870W x 990D x 2092mmH
People	1

## Ventilation

QTY of fans	4 total; 2 draw in through side, 2 draw out through ceiling
Air flow rate	117.2CFM
Input	24V DC
User motion detected to	30sec / 3min / 10min

## Power

Mains supply	10 amps
Cord from booth	3 metres
Output	2 gang; 1x Power, 1x USB A, 1x USB C

## Socket options



## Lighting

Power usage	9.6W
Input	24V
Lumen output	85lm/W
LED options	Natural white
User motion detected to	30sec / 3min / 10min

## Motion sensor

Passive infrared sensor	
Running time options	30sec / 3min / 10min

## VC light

Natural white	
Touch activated dimmable	

## PET

Composition	100% PET, 60-68% recycled
Sustainability	Greentag certified. Greenrate level: A
VOC Emission	<0.004mg/m <sup>2</sup> /hr

## Structure

Faced plywood	64mm hoop pine plywood
Internal	Acoustic wall paneling
External	Acoustic wall covering

## Door

Door dimensions	846W x 2069H x 8mm frameless toughened glass
Door weight	20kg
Disabled access	No wheelchair access - disability accessible
Door hardware	Stainless steel or matte black
Drop seal	Engaged when door is closed

## Floor

Levelling	Adjustable glides
Floor	No floor - sealed perimeter

## Install

Time	2-3 hours
People required	2

## Fire safety

Fire alarm	Provision provided on request
Smoke detection	Provision provided on request
Sprinkler compatible	Provision provided on request

## Cleaning

PET / Upholstery	Refer to product care and maintenance guide
Timber	Refer to product care and maintenance guide



# OPTIONS & FINISHES

## RETREAT 1.0 back options



Glass back



PET back

## RETREAT 1.0 table options



Fixed table

Dimensions 880x320x32mm  
 Height from floor 1050mmH  
 Worktop finish White or black worktop  
 Edge finish Natural or black stain



Fold down table

Dimensions 880x320x18mm  
 Height from floor 1050mmH  
 Worktop finish White or black worktop  
 Edge finish White or black  
 Shelf finish Natural or black stain edge

## Timber finishes



Natural



Black Stain



Blazer Silcoates

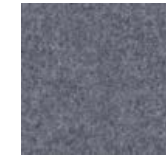

Blazer Surrey



Blazer St Andrews

## Interior / exterior finishes



454



908



101



442



402



444



447



365



468



580



384



349



330



269



542



550



124



167



487



274



551



660

\*Contact Square-Bear Acoustics for custom colour options.

# RETREAT 1.05

## Technical Specifications

Get creative with floor plans using RETREAT 1.05. Designed for both flexibility and floorspace practicality, RETREAT 1.05 has a unique aesthetic that can be used alone or with other products from the RETREAT range. With one flat side and one tapered, RETREAT 1.05 can be placed against a wall or corner, or can be incorporated into a suite of Square Bear products including multi-sized RETREAT pods, mobile storage, planters, and whiteboards.



### VENTILATION

Low noise, sensor-controlled ventilation system with constant air exchange via top and base outlets with internal fan systems.



### ENVIRONMENTAL DATA

60% recycled content to PET. Sustainably sourced timber FSC timber available on request.



### SERVICES

Seamless mechanical services integration with allowances for a sprinkler and smoke detector.



### INSTALLATION

RETREAT 1.05 requires 2 men for 2-3 hours.



### VC LIGHT

Dimmable touch activated



### PERFORMANCE

Acoustic materials used for internal and external surfaces provide ambient noise reduction and minimise noise reverberation from the surrounding office.



### ACCESS

RETREAT sits flush on the floor with a rubber seal for acoustic protection, there is no step or floor base to impede entry.



### PLUG AND PLAY

Quick connection to mains power using standard sockets.



### WARRANTY

7 year structural warranty.



Square Bear

RETREAT 1.05  
TECHNICAL SPECIFICATIONS

sales@square-bear.com  
www.square-bear.com



# PRODUCT DATA

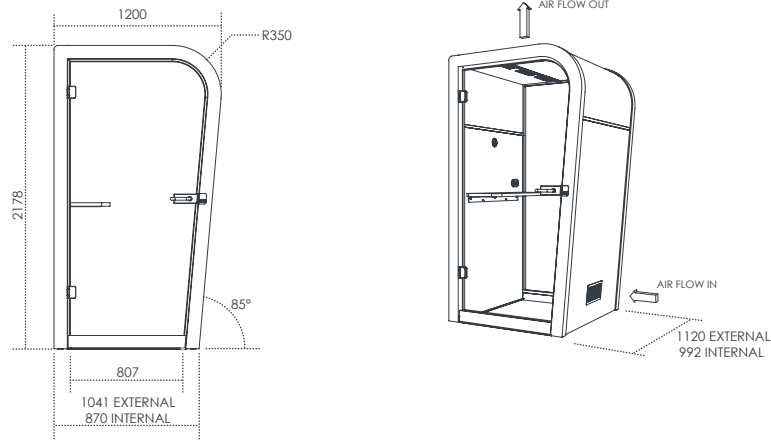

## Product dimensions

External dimensions	1040/1200W x 1120D x 2178mmH
Internal dimensions	870/1035W x 990D x 2092mmH
People	1

## Ventilation

QTY of fans	4 total; 2 draw in through side, 2 draw out through ceiling
Air flow rate	117.2CFM
Input	24V DC
User motion detected to	30sec / 3min / 10min

## Power

Mains supply	10 amps
Cord from booth	3 metres
Output	2 gang; 1x Power, 1x USB A, 1x USB C

## Socket options



## Lighting

Input	24V
Lumen output	85lm/W
LED options	Natural white
User motion detected to	30sec / 3min / 10min

## Motion sensor

Passive infrared sensor	
Running time options	30sec / 3min / 10min

## VC light

Natural white	
Touch activated dimmable	

## PET

Composition	100% PET, 60-68% recycled
Sustainability	Greentag certified. Greenrate level: A
VOC Emission	<0.004mg/m <sup>3</sup> /hr

## Structure

Faced plywood	64mm hoop pine plywood
Internal	Acoustic wall paneling
External	Acoustic wall covering

## Door

Door dimensions	840/998W x 2068H x 8mm frameless toughened glass
Door weight	25kg
Disabled access	No wheelchair access - disability accessible
Door hardware	Stainless steel or matte black
Drop seal	Engaged when door is closed

## Floor

Levelling	Adjustable glides
Floor	No floor - sealed perimeter

## Install

Time	2-3 hours
People required	2

## Fire safety

Fire alarm	Provision provided on request
Smoke detection	Provision provided on request
Sprinkler compatible	Provision provided on request

## Cleaning

PET / Upholstery	Refer to product care and maintenance guide
Timber	Refer to product care and maintenance guide

# OPTIONS & FINISHES

## RETREAT 1.05 back options



Glass back



PET back

## RETREAT 1.05 table options



Fixed table

Dimensions 880x320x32mm  
 Height from floor 1050mmH  
 Worktop finish White or black worktop  
 Edge finish Natural or black stain



Fold down table

Dimensions 880x320x18mm  
 Height from floor 1050mmH  
 Worktop finish White or black worktop  
 Edge finish White or black  
 Shelf finish Natural or black stain edge

## Timber finishes



Natural



Black Stain

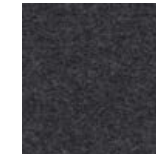

Blazer Silcoates

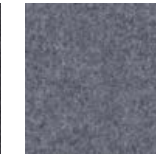

Blazer Surrey



Blazer St Andrews

## Interior / exterior finishes



454



908



101



442



402



444



447



365



468



580



384



349



330



269



542



550



124



167



487



274



551



660

\*Contact Square-Bear Acoustics for custom colour options.



# RETREAT 1.1

## Technical Specifications

Designed for one person to work within, or two for a quick chat, RETREAT 1.1 is manufactured using sustainable timber frames and acoustic fabric panels in a range of colour combinations. Table top options are available as either a fixed or drop down version, and an inbuilt light with sensor controlled LED provides energy efficiency. Acoustic panels are used on both the interior and exterior to maximise acoustic performance. RETREAT comes without a floor base to allow for all users to enter the space without hinderance.



### VENTILATION

Low noise, sensor-controlled ventilation system with constant air exchange via top and base outlets with internal fan systems.



### ENVIRONMENTAL DATA

60% recycled content to PET.  
Sustainably sourced timber FSC timber available on request.



### SERVICES

Seamless mechanical services integration with allowances for a sprinkler and smoke detector.



### VC LIGHT

Dimmable touch activated



### PERFORMANCE

Acoustic materials used for internal and external surfaces provide ambient noise reduction and minimise noise reverberation from the surrounding office.



### ACCESS

RETREAT sits flush on the floor with a rubber seal for acoustic protection, there is no step or floor base to incumber entry.



### PLUG AND PLAY

Quick connection to mains power using standard sockets.



### WARRANTY

7 year structural warranty.



### INSTALLATION

RETREAT 1.1 requires 2 men for 2-3 hours.



# PRODUCT DATA

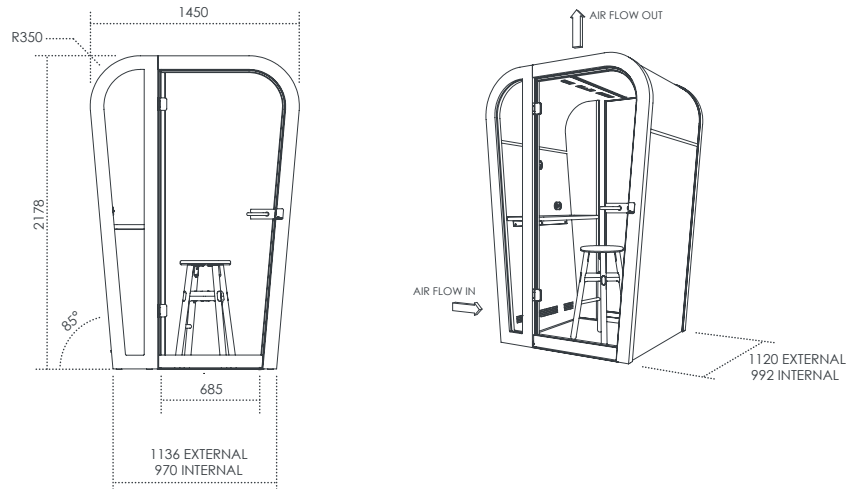

## Product dimensions

External dimensions	1136/1450W x 1120D x 2178mmH
Internal dimensions	970/1286W x 990D x 2092mmH
People	1-2

## Ventilation

QTY of fans	4 total; 2 draw in through side, 2 draw out through ceiling
Air flow rate	117.2CFM
Input	24V DC
User motion detected to	30sec / 3min / 10min

## Power

Mains supply	10 amps
Cord from booth	3 metres
Output	2 gang; 1x Power, 1x USB A, 1x USB C

## Socket options



## Lighting

Input	24V
Lumen output	85lm/W
LED options	Natural white
User motion detected to	30sec / 3min / 10min

## Motion sensor

Passive infrared sensor	
Running time options	30sec / 3min / 10min

## VC light

Natural white	
Touch activated dimmable	

## PET

Composition	100% PET, 60-68% recycled
Sustainability	Greentag certified. Greenrate level: A
VOC Emission	<0.004mg/m <sup>3</sup> /hr

## Structure

Faced plywood	64mm hoop pine plywood
Internal	Acoustic wall paneling
External	Acoustic wall covering

## Door

Door dimensions	718/876W x 2068H x 8mm frameless toughened glass
Door weight	23kg
Disabled access	No wheelchair access - disability accessible
Door hardware	Stainless steel or matte black
Drop seal	Engaged when door is closed

## Floor

Levelling	Adjustable glides
Floor	No floor - sealed perimeter

## Install

Time	2-3 hours
People required	2

## Fire safety

Fire alarm	Provision provided on request
Smoke detection	Provision provided on request
Sprinkler compatible	Provision provided on request

## Cleaning

PET / Upholstery	Refer to product care and maintenance guide
Timber	Refer to product care and maintenance guide



# OPTIONS & FINISHES

## RETREAT 1.1 back options



Glass back



PET back

## RETREAT 1.1 table options



Fixed table

Dimensions 880x320x32mm  
 Height from floor 1050mmH  
 Worktop finish White or black worktop  
 Edge finish Natural or black stain



Fold down table

Dimensions 880x320x18mm  
 Height from floor 1050mmH  
 Worktop finish White or black worktop  
 Edge finish White or black  
 Shelf finish Natural or black stain edge

## Timber finishes



Natural



Black Stain



Blazer Silcoates

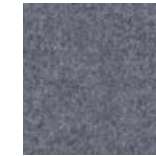

Blazer Surrey



Blazer St Andrews

## Interior / exterior finishes



454



908



101



442



402



444



447



365



468



580



384



349



330



269



542



550



124



167



487



274



551



660

\*Contact Square-Bear Acoustics for custom colour options.

# RETREAT 1.15

## Technical Specifications

At Square Bear, we know that people work better when they feel better, and we have designed RETREAT 1.15 to provide just that little bit more space than the traditional phone booth style acoustic pods without being too large for workplace floor areas. RETREAT 1.15 is a true versatile member of the RETREAT family - generous in size for one person to be comfortable for longer periods of time, and ideal for two people to have a quick meeting.

 **VENTILATION**  
Low noise, sensor-controlled ventilation system with constant air exchange via top and base outlets with internal fan systems.

 **ENVIRONMENTAL DATA**  
60% recycled content to PET.  
Sustainably sourced timber FSC timber available on request.

 **SERVICES**  
Seamless mechanical services integration with allowances for a sprinkler and smoke detector.

 **INSTALLATION**  
RETREAT 1.15 requires 2 men for 2-3 hours.

 **VC LIGHT**  
Dimmable touch activated

 **PERFORMANCE**  
Acoustic materials used for internal and external surfaces provide ambient noise reduction and minimise noise reverberation from the surrounding office.

 **ACCESS**  
RETREAT sits flush on the floor with a rubber seal for acoustic protection, there is no step or floor base to impede entry.

 **PLUG AND PLAY**  
Quick connection to mains power using standard sockets.

 **WARRANTY**  
7 year structural warranty.



# PRODUCT DATA

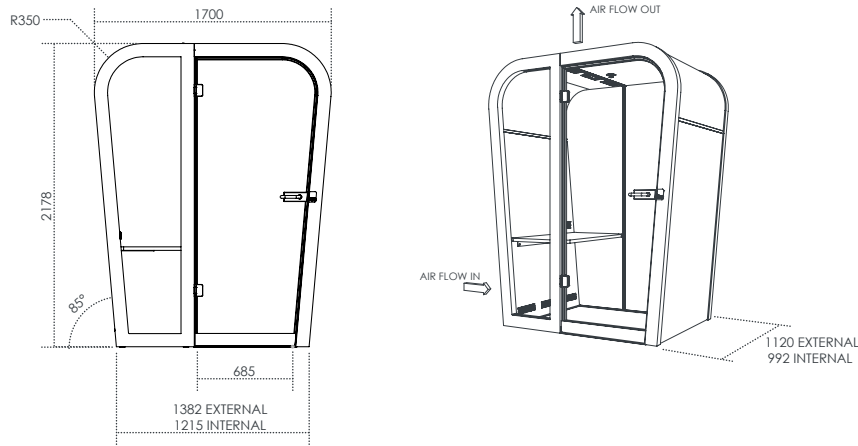

## Product dimensions

External dimensions	1380/1700W x 1120D x 2178mmH
Internal dimensions	1215/1530W x 990D x 2092mmH
People	1-2

## Ventilation

QTY of fans	4 total; 2 draw in through side, 2 draw out through ceiling
Air flow rate	117.2CFM
Input	24V DC
User motion detected to	30sec / 3min / 10min

## Power

Mains supply	10 amps
Cord from booth	3 metres
Output	2 gang; 1x Power, 1x USB A, 1x USB C

## Socket options

AUS	UK	USB A, USB C
		

## Lighting

Input	24V
Lumen output	85lm/W
LED options	Natural white
User motion detected to	30sec / 3min / 10min

## Motion sensor

Passive infrared sensor	
Running time options	30sec / 3min / 10min

## VC light

Natural white	
Touch activated dimmable	

## PET

Composition	100% PET, 60-68% recycled
Sustainability	Greentag certified. Greenrate level: A
VOC Emission	<0.004mg/m <sup>3</sup> /hr

## Structure

Faced plywood	64mm hoop pine plywood
Internal	Acoustic wall paneling
External	Acoustic wall covering

## Door

Door dimensions	718/876W x 2068H x 8mm frameless toughened glass
Door weight	23kg
Disabled access	No wheelchair access - disability accessible
Door hardware	Stainless steel or matte black
Drop seal	Engaged when door is closed

## Floor

Levelling	Adjustable glides
Floor	No floor - sealed perimeter

## Install

Time	2-3 hours
People required	2

## Fire safety

Fire alarm	Provision provided on request
Smoke detection	Provision provided on request
Sprinkler compatible	Provision provided on request

## Cleaning

PET / Upholstery	Refer to product care and maintenance guide
Timber	Refer to product care and maintenance guide



# OPTIONS & FINISHES

## Timber finishes



Natural



Black Stain



Blazer Silcoates

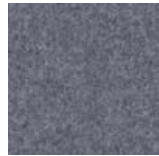

Blazer Surrey



Blazer St Andrews

## Stool upholstery finishes

## Interior / exterior finishes



454



908



101



442



402



444



447



365



468



580



384



349



330



269



542



550



124



167



487



274



551



660

\*Contact Square-Bear Acoustics for custom colour options.

# RETREAT 2.1

## Technical Specifications

RETREAT 2.1 is perfect for a small meeting or collaborative workspace. Providing room for up to four people, RETREAT 2.1 is designed for task meetings, private conversations, and a place to escape the busy work environment. Quick to install, the 2.1 workspace is ideal for any workplace setting.



### VENTILATION

Low noise, sensor-controlled ventilation system with constant air exchange via top and base outlets with internal fan systems.



### ENVIRONMENTAL DATA

60% recycled content to PET. Sustainably sourced timber FSC timber available on request.



### SERVICES

Seamless mechanical services integration with allowances for sprinklers and smoke detector.



### INSTALLATION

RETREAT 2.1 requires 2 men for 3-4 hours.



### OVERHEAD DOWN LIGHTS

Dimmable touch activated



### PERFORMANCE

Acoustic materials used for internal and external surfaces provide ambient noise reduction and minimise noise reverberation from the surrounding office.



### ACCESS

RETREAT sits flush on the floor with a rubber seal for acoustic protection, there is no step or floor base to impede entry.



### PLUG AND PLAY

Quick connection to mains power using standard sockets.



### WARRANTY

7 year structural warranty.



# PRODUCT DATA

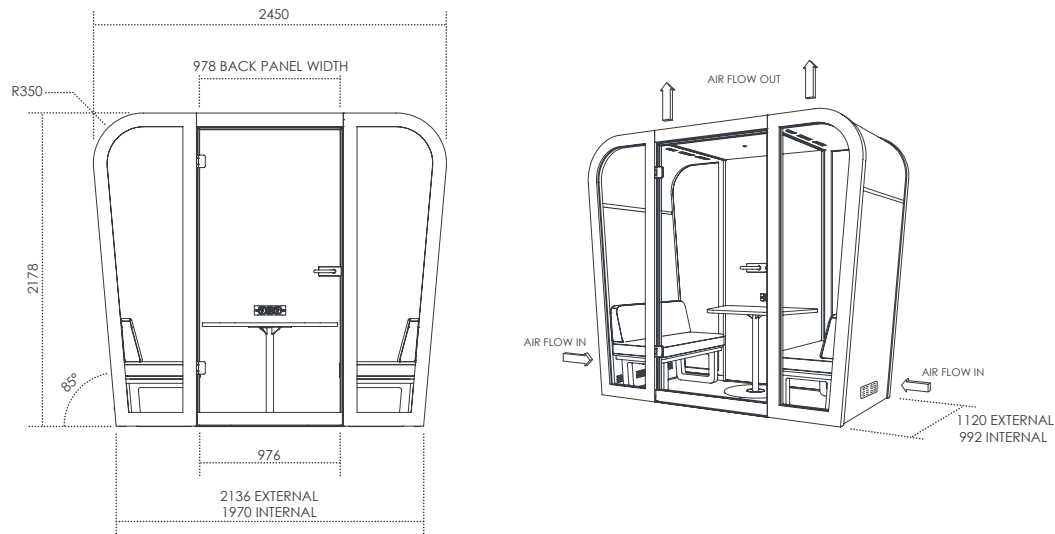

## Product dimensions

External dimensions	2135/2450W x 1120D x 2180mmH
Internal dimensions	1970/2286W x 990D x 2092mmH
People	2-4

## Ventilation

QTY of fans	8 total; 4 draw in through side, 4 draw out through ceiling
Air flow rate	117.2CFM
Input	24V DC
User motion detected to	30sec / 3min / 10min

## Power

Mains supply	10 amps
Cord from booth	3 metres
Output	3 gang; 2x Power, 1x USB A, 1x USB C

## Socket options

AUS	UK	USB A, USB C

## Lighting

Input	24V
Lumen output	85lm/W
LED options	Natural white
User motion detected to	30sec / 3min / 10min

## Motion sensor

Passive infrared sensor	
Running time options	30sec / 3min / 10min

## Overhead down light

Natural white	
Touch activated dimmable	

## PET

Composition	100% PET, 60-68% recycled
Sustainability	Greentag certified. Greenrate level: A
VOC emission	<0.004mg/m <sup>2</sup> /hr

## Structure

Faced plywood	64mm hoop pine plywood
Internal	Acoustic wall paneling
External	Acoustic wall covering

## Door

Door dimensions	1009W x 2068H x 8mm frameless toughened glass
Door weight	40kg
Disabled access	Wheelchair accessible
Door hardware	Stainless steel or matte black
Drop seal	Engaged when door is closed

## Floor

Levelling	Adjustable glides
Floor	No floor - sealed perimeter

## Install

Time	3-4 hours
People required	2

## Fire safety

Fire alarm	Provision provided on request
Smoke detection	Provision provided on request
Sprinkler compatible	Provision provided on request

## Cleaning

PET / Upholstery	Refer to product care and maintenance guide
Timber	Refer to product care and maintenance guide



# OPTIONS & FINISHES

## RETREAT 2.1 back options



Glass back



PET back

## RETREAT 2.1 table options



Centre table low

Dimensions 940x600x25mm  
 Height from floor 720mmH  
 Worktop finish White or black worktop  
 Edge finish Natural or black stain



Centre table high

Dimensions 940x600x25mm  
 Height from floor 1050mmH  
 Worktop finish White or black worktop  
 Edge finish Natural or black stain

## Timber finishes



Natural



Black Stain

## Sofa upholstery finishes



Blazer Silcoates

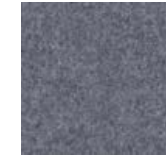

Blazer Surrey



Blazer St Andrews

## Interior / exterior finishes



454



908



101



442



402



444



447



365



468



580



384



349



330



269



542



550



124



167



487



274



551



660

\*Contact Square-Bear Acoustics for custom colour options.

# RETREAT 2.2

## Technical Specifications

For meetings of up to six people, RETREAT 2.2 accommodates various furniture styles, configurations, and integrated AV and IT options. RETREAT 2.2 is ideal for large meetings and collaborative tasks.

 **VENTILATION**  
Low noise, sensor-controlled ventilation system with constant air exchange via top and base outlets with internal fan systems.

 **ENVIRONMENTAL DATA**  
60% recycled content to PET.  
Sustainably sourced timber FSC timber available on request.

 **SERVICES**  
Seamless mechanical services integration with allowances for sprinklers and smoke detector.

 **INSTALLATION**  
RETREAT 2.2 requires 2 men for 4-5 hours.

 **OVERHEAD DOWN LIGHTS**  
Dimmable touch activated

 **PERFORMANCE**  
Acoustic materials used for internal and external surfaces provide ambient noise reduction and minimise noise reverberation from the surrounding office.

 **ACCESS**  
RETREAT sits flush on the floor with a rubber seal for acoustic protection, there is no step or floor base to impede entry.

 **PLUG AND PLAY**  
Quick connection to mains power using standard sockets.

 **WARRANTY**  
7 year structural warranty.



# PRODUCT DATA

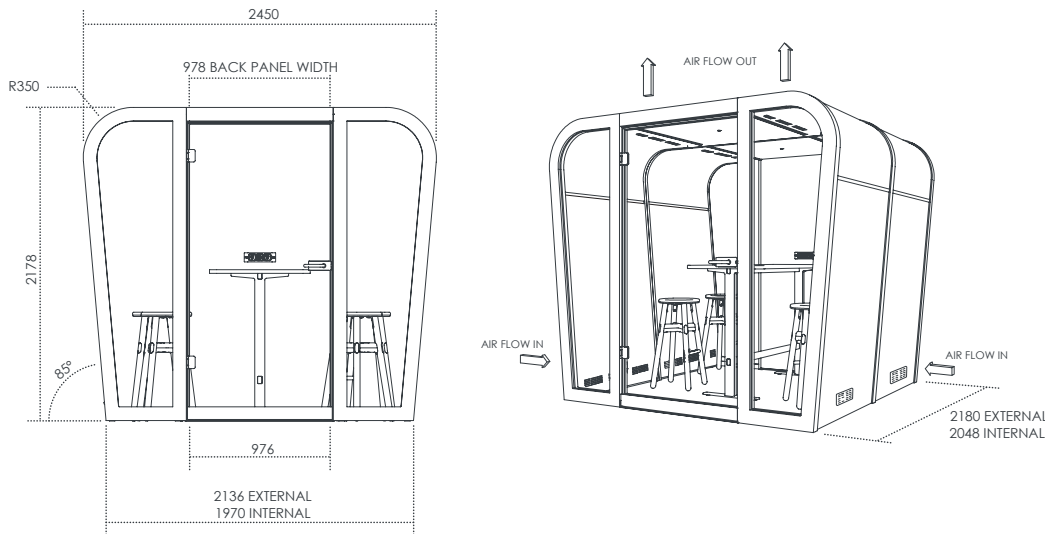

## Product dimensions

External dimensions	2135/2450W x 2180D x 2180mmH
Internal dimensions	1970/2286W x 2050D x 2092mmH
People	4-6

## Ventilation

QTY of fans	16 total; 8 draw in through side, 8 draw out through ceiling
Air flow rate	234.4 CFM
Input	24V DC
User motion detected to	30sec / 3min / 10min

## Power

Mains supply	10 amps
Cord from booth	3 metres
Output	3 gang; 2x Power, 1x USB A, 1x USB C

## Socket options

AUS	UK	USB A, USB C

## Lighting

Input	24V
Lumen output	85lm/W
LED options	Natural white
User motion detected to	30sec / 3min / 10min

## Motion sensor

Passive infrared sensor	
Running time options	30sec / 3min / 10min

## Overhead down light

Natural white	
Touch activated dimmable	

## PET

Composition	100% PET, 60-68% recycled
Sustainability	Greentag certified. Greenrate level: A
VOC emission	<0.004mg/m <sup>2</sup> /hr

## Structure

Faced plywood	64mm hoop pine plywood
Internal	Acoustic wall paneling
External	Acoustic wall covering

## Door

Door dimensions	1009W x 2068H x 8mm frameless toughened glass
Door weight	40kg
Disabled access	Wheelchair accessible
Door hardware	Stainless steel or matte black
Drop seal	Engaged when door is closed

## Floor

Levelling	Adjustable glides
Floor	No floor - sealed perimeter

## Install

Time	4-5 hours
People required	2

## Fire safety

Fire alarm	Provision provided on request
Smoke detection	Provision provided on request
Sprinkler compatible	Provision provided on request

## Cleaning

PET / Upholstery	Refer to product care and maintenance guide
Timber	Refer to product care and maintenance guide



# OPTIONS & FINISHES

## RETREAT 2.2 back options



Glass back



PET back

## RETREAT 2.2 table options



Meeting table low

Dimensions 1500x700x25mm  
 Height from floor 720mmH  
 Worktop finish White or black worktop  
 Edge finish Natural or black stain  
 Base finish Natural or black stain



Meeting table high

Dimensions 1500x700x25mm  
 Height from floor 1050mmH  
 Worktop finish White or black worktop  
 Edge finish Natural or black stain  
 Base finish Natural or black stain

## Timber finishes



Natural



Black Stain



Blazer Silcoates

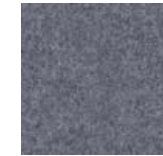

Blazer Surrey



Blazer St Andrews

## Interior / exterior finishes



454



908



101



442



402



444



447



365



468



580



384



349



330



269



542



550



124



167



487



274



551



660

\*Contact Square-Bear Acoustics for custom colour options.

# RETREAT 2.3

## Technical Specifications

For meetings of up to six people, RETREAT 2.3 accommodates various furniture styles, configurations, and integrated AV and IT options. RETREAT 2.3 is ideal for large meetings and collaborative tasks.

 **VENTILATION**  
Low noise, sensor-controlled ventilation system with constant air exchange via top and base outlets with internal fan systems.

 **ENVIRONMENTAL DATA**  
60% recycled content to PET.  
Sustainably sourced timber FSC timber available on request.

 **SERVICES**  
Seamless mechanical services integration with allowances for sprinklers and smoke detector.

 **INSTALLATION**  
RETREAT 2.3 requires 2 men for 5-6 hours.

 **OVERHEAD DOWN LIGHTS**  
Dimmable touch activated

 **PERFORMANCE**  
Acoustic materials used for internal and external surfaces provide ambient noise reduction and minimise noise reverberation from the surrounding office.

 **ACCESS**  
RETREAT sits flush on the floor with a rubber seal for acoustic protection, there is no step or floor base to impede entry.

 **PLUG AND PLAY**  
Quick connection to mains power using standard sockets.

 **WARRANTY**  
7 year structural warranty.



# PRODUCT DATA

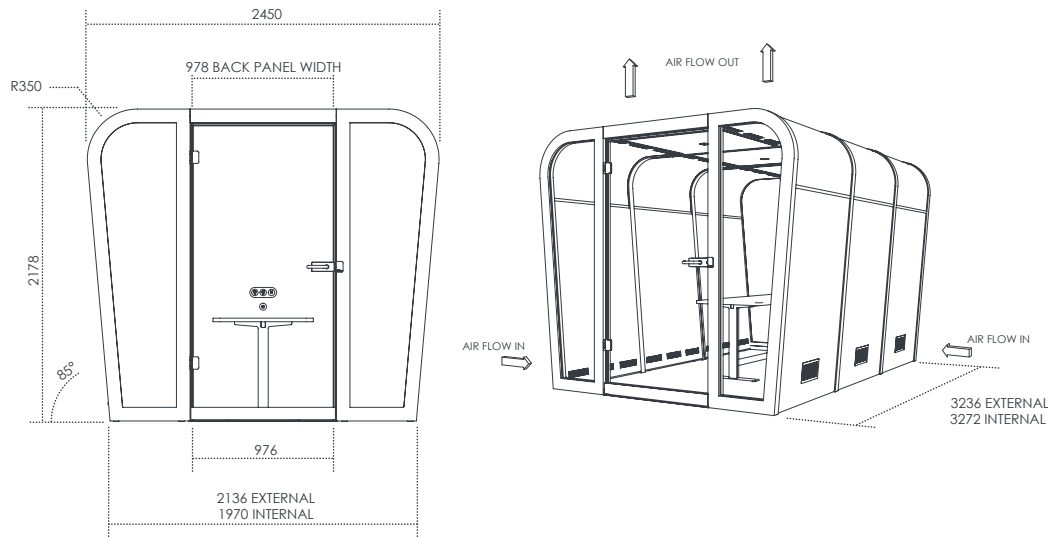

## Product dimensions

External dimensions	2135/2450W x 3236D x 2180mmH
Internal dimensions	1970/2286W x 3272D x 2092mmH
People	6-8

## Ventilation

QTY of fans	24 total; 12 draw in through side, 12 draw out through ceiling
Air flow rate	234.4 CFM
Input	24V DC
User motion detected to	30sec / 3min / 10min

## Power

Mains supply	10 amps
Cord from booth	3 metres
Output	3 gang; 2x Power, 1x USB A, 1x USB C

## Socket options

AUS	UK	USB A, USB C

## Lighting

Input	24V
Lumen output	85lm/W
LED options	Natural white
User motion detected to	30sec / 3min / 10min

## Motion sensor

Passive infrared sensor	
Running time options	30sec / 3min / 10min

## Overhead down light

Natural white	
Touch activated dimmable	

## PET

Composition	100% PET, 60-68% recycled
Sustainability	Greentag certified. Greenrate level: A
VOC emission	<0.004mg/m <sup>2</sup> /hr

## Structure

Faced plywood	64mm hoop pine plywood
Internal	Acoustic wall paneling
External	Acoustic wall covering

## Door

Door dimensions	1009W x 2068H x 8mm frameless toughened glass
Door weight	40kg
Disabled access	Wheelchair accessible
Door hardware	Stainless steel or matte black
Drop seal	Engaged when door is closed

## Floor

Levelling	Adjustable glides
Floor	No floor - sealed perimeter

## Install

Time	5-6 hours
People required	2

## Fire safety

Fire alarm	Provision provided on request
Smoke detection	Provision provided on request
Sprinkler compatible	Provision provided on request

## Cleaning

PET / Upholstery	Refer to product care and maintenance guide
Timber	Refer to product care and maintenance guide

# OPTIONS & FINISHES

## RETREAT 2.3 back options



Glass back



PET back

## RETREAT 2.2 table options



Meeting table low

Dimensions 2100x700x25mm  
 Height from floor 720mmH  
 Worktop finish White or black worktop  
 Edge finish Natural or black stain  
 Base finish Natural or black stain



Meeting table high

Dimensions 2100x700x25mm  
 Height from floor 1050mmH  
 Worktop finish White or black worktop  
 Edge finish Natural or black stain  
 Base finish Natural or black stain

## Timber finishes



Natural



Black Stain

## Sofa upholstery finishes



Blazer Silcoates

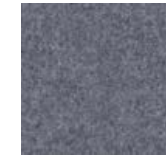

Blazer Surrey



Blazer St Andrews

## Interior / exterior finishes



454



908



101



442



402



444



447



365



468



580



384



349



330



269



542



550



124



167



487



274



551



660

\*Contact Square-Bear Acoustics for custom colour options.



# 2.2 OPEN RETREAT

## Technical Specifications

Providing a space to escape without the formality of a meeting room, OPEN RETREAT can integrate into workplace designs as an additional meeting zone, quiet space, or for team-work.

**PERFORMANCE**  
Acoustic materials used for internal and external surfaces provide ambient noise reduction and minimised noise reverberation from the surrounding office.

**ENVIRONMENTAL DATA**  
60% recycled content to PET.  
Sustainably sourced timber FSC timber available on request.

**PLUG AND PLAY**  
Quick connection to mains power using standard sockets.

**OVERHEAD DOWN LIGHTS**  
Dimmable touch activated

**ACCESS**  
RETREAT sits flush on the floor with a rubber seal for acoustic protection, there is no step or floor base to impede entry.

**SERVICES**  
Seamless mechanical services integration with allowances for sprinklers and smoke detector.

**INSTALLATION**  
2.2 OPEN RETREAT requires 2 men for 4-5 hours.

**WARRANTY**  
7 year structural warranty.



# PRODUCT DATA

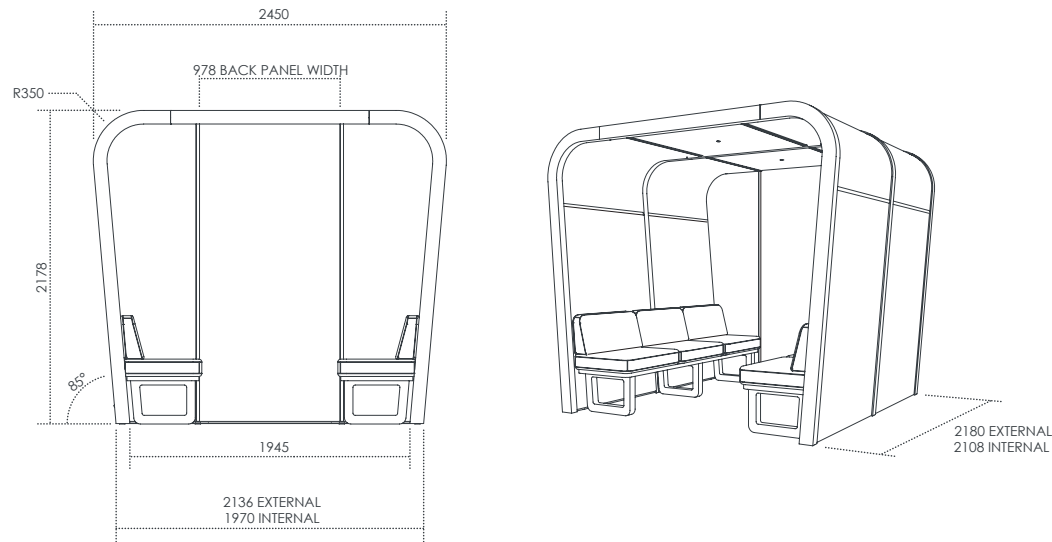

## Product dimensions

External dimensions	2135/2450W x 2180D x 2180mmH
Internal dimensions	1970/2286W x 2050D x 2092mmH
People	4-6

## Power

Mains supply	10 amps
Cord from booth	3 metres
Output	3 gang; 2x Power, 1x USB A, 1x USB C

## Socket options



## Lighting

Input	24V
Lumen output	85lm/W
LED options	Natural white
User motion detected to	30sec / 3min / 10min

## Motion sensor

Passive infrared sensor	
Running time options	30sec / 3min / 10min

## Overhead down light

Natural white	
Touch activated dimmable	

## PET

Composition	100% PET, 60-68% recycled
Sustainability	Greentag certified. Greenrate level: A
VOC Emission	<0.004mg/m <sup>2</sup> /hr

## Structure

Faced plywood	64mm hoop pine plywood
Internal	Acoustic wall paneling
External	Acoustic wall covering

## Floor

Levelling	Adjustable glides
-----------	-------------------

## Install

Time	4-5 hours
People required	2

## Fire safety

Fire alarm	Provision provided on request
Smoke detection	Provision provided on request
Sprinkler compatible	Provision provided on request

## Cleaning

PET / Upholstery	Refer to product care and maintenance guide
Timber	Refer to product care and maintenance guide

# OPTIONS & FINISHES

## 2.2 OPEN RETREAT furniture options



Meeting table low or high  
 Dimensions 1500x700x25mm  
 Height from floor 720mmH / 1050mmH  
 Worktop finish White or black worktop  
 Edge finish Natural or black stain  
 Base finish Natural or black stain



RETREAT 2.2 Sofa  
 Overall dimensions 2050Dx564Wx725mmH  
 Seat height 450mmH  
 backrest height 725mmH  
 Base edge finish Natural or black stain  
 Leg finish Natural or black stain

### Timber finishes



Natural



Black Stain

### Sofa upholstery finishes



Blazer Silcoates



Blazer Surrey



Blazer St Andrews

### Interior / exterior finishes



454



908



101



442



402



444



447



365



468



580



384



349



330



269



542



550



124



167



487



274



551



660

\*Contact Square-Bear Acoustics for custom colour options.

# Sustainability Statement

At Square Bear, we understand the importance of sustainability. We want to have a positive impact on our employees, our community, and our environment – we want to do the right thing because we are passionate, not because of social trends.

This involves minimising the environmental impacts of our products and manufacturing processes, providing a safe and healthy workplace for our employees, and ensuring that basic human and labour rights are extended to workers in our business supply chains.



## **Our Sustainable Sourcing Program**

We will uphold human rights and environmental concerns towards eradicating modern slavery. We want to understand how we can help our suppliers become more sustainable in terms of human rights and environmental performance.



## **Our Human Rights Program**

We are developing a culture that respects the United Nations' Universal Declaration of Human Rights and Guiding Principles on Business and Human Rights, and the International Labour Organisation's Declaration on Fundamental Principles and Rights at Work.



## **Our Environmental Program**

We are committed to reducing waste and energy, ensuring staff are aware of their responsibilities, and most importantly complying with environmental legislation. We are working towards understanding the impact of our products, conducting supply chain due diligence and approval of ecolabelling certification.

**We are strong believers in purposeful partnerships.**

**We take a global perspective.**

**We care deeply about the future of the planet.**



# Environmental Policy

Square Bear is an Australian-owned company who design and manufacture products that enhance the workplace. We focus on stress reduction in the workplace including noise, distraction and air pollution, but also consider the need for flexible and mobile solutions that can be used in numerous ways for collaborative and individual work styles.

Square Bear is a business committed to creating work environments that allow people to think, focus, and achieve, while recognising that productivity brings satisfaction on all levels.

We are dedicated to sustainable design and development, and to minimising the environmental impacts of our products, manufacturing processes, and services.

We are committed to:

- Complying with all applicable environmental laws, regulations, and standards
- Meeting the requirements of Australian Type I (third-party) ecolabelling standards
- Reducing waste through our recycling program
- Setting environmental objectives

- Considering environmental issues in business strategies, programs, and initiatives
- Educating staff and stakeholders about our environmental objectives, programs, and initiatives
- Implementing pollution prevention practices
- Reducing energy consumption



- Conducting quality assurance to minimise waste in manufacturing of all product components
- Taking a life-cycle approach to the design and development of our products
- Conducting our business with due consideration for all of our stakeholders
- Striving for continual improvement to enhance environmental performance

By making these commitments, we believe we are striving to be our best, and produce best-practice products so that your employees can function at their best.



Dean Kuch  
Managing Director

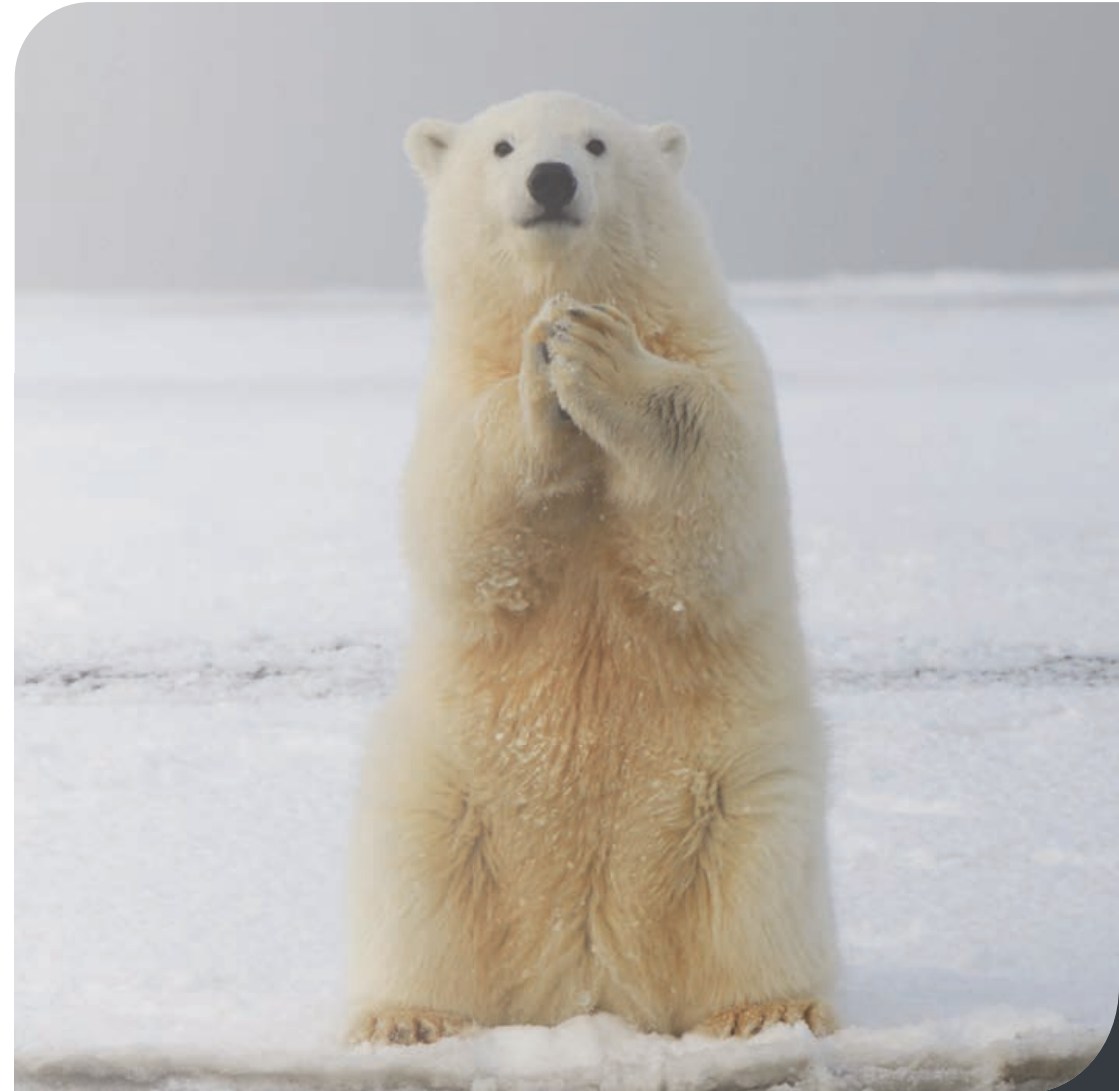

## **SQUARE BEAR**

© Copyright 2021

All Rights Reserved

### **HEAD OFFICE**

Unit 6/80 Jedda Road, Prestons

New South Wales 2170, Australia

P: +61 (0)2 9189 1444

[sales@square-bear.com](mailto:sales@square-bear.com)

### **SYDNEY SHOWROOM**

Level 3/140 William Street, Woolloomooloo

New South Wales 2011, Australia

[www.square-bear.com](http://www.square-bear.com)